



XCITE Owner's Manual

1200T-10 Continuous Rotation Inertial Exciter System

- ES-320 Exciter Head
 - 1104-MOD-ROT Master Controller
 - 1201B-(DP) Dual Pressure Hydraulic Power Supply
-

Copyright 1997
Xcite Systems Corporation

This document contains proprietary information of Xcite Systems Corporation and is tendered subject to the conditions that the information (a) be retained in confidence (b) not be reproduced or copied in whole or in part and (c) not be used or incorporated into any product except under an express written agreement with Xcite Systems Corporation.

Table of Contents

- 1. Warranty P-7**
 - 1.1. Xcite Products..... P-7
 - 1.2. Third Party Hardware Products..... P-7
 - 1.3. IMPORTANT LIMITATIONS P-7
 - 1.4. NOTICE OF LIMITED WARRANTY P-8
- 2. Receiving..... P-8**
 - 2.1. Receiving Inspection Procedure P-8
 - 2.2. Shipping Container P-8

ES-320 Setup and Operation

- 1. Introduction..... S&O-1**
- 2. System Description S&O-1**
- 3. Setup Procedure S&O-3**
 - 3.1. Mounting the ES-320 Exciter Head to the Test Structure..... S&O-3
 - 3.2. Hydraulic Power Supply Commissioning Procedure..... S&O-4
 - 3.3. Starting the Hydraulic Power Supply S&O-4
 - 3.4. Mounting the Magnetic Pickup Bracket..... S&O-5
 - 3.5. Hydraulic Hookup..... S&O-6
 - 3.6. Cable Hookup S&O-7
- 4. Operation Procedure S&O-9**
 - 4.1. Switch Settings S&O-9
- 5. Shutdown Procedures..... S&O-10**
- 6. Troubleshooting..... S&O-11**
- 7. Storage Instructions..... S&O-12**

ES-320 Exciter Head

- 1. Introduction..... EH-1**
- 2. System Components EH-2**
 - 2.1. Actuator..... EH-2
 - 2.2. Rotating Union EH-2
 - 2.3. Pressure Transducer..... EH-2
 - 2.4. Magnetc Pick-Ups..... EH-2
 - 2.5. Servovalve EH-2
- 3. Specifications EH-2**
- 4. Head Operating Instructions EH-3**
- 5. Drawings..... EH-3**

1201B Dual Pressure Hydraulic Power Supply

- 1. **Introduction.....HPS-1**
- 2. **Commissioning Procedure.....HPS-1**
 - 2.1. Initial Setup of Hydraulic Power SupplyHPS-1
 - 2.2. Starting the Hydraulic Power SupplyHPS-2
 - 2.3. Hydraulic Hookup.....HPS-3
- 3. **Theory of OperationHPS-3**
 - 3.1. Hydraulic SystemHPS-3
 - 3.2. Electrical SystemHPS-4
- 4. **Description.....HPS-5**
 - 4.1. Major Components.....HPS-5
 - 4.2. Control Components.....HPS-5
 - 4.3. Monitoring DevicesHPS-6
- 5. **Care and Maintenance.....HPS-7**
 - 5.1. Operating CareHPS-7
 - 5.2. MaintenanceHPS-8
- 6. **Troubleshooting.....HPS-8**
 - 6.1. Unit OverheatsHPS-8
 - 6.2. Pump de-energizes.....HPS-8
- 7. **SpecificationsHPS-9**
- 8. **Drawings.....HPS-9**

Master Controller

- 1. **Introduction.....MC-1**
- 2. **Theory of OperationMC-1**
 - 2.1. Conf gurations.....MC-1
 - 2.1.1. Single Loop.....MC-1
 - 2.1.2. Dual LoopMC-1
- 3. **Description.....MC-2**
 - 3.1. Front PanelMC-3
 - 3.1.1. Static Signal Level Meter (M-101)MC-3
 - 3.1.2. Static Set Point (R301)MC-3
 - 3.1.3. Dynamic Signal Level Meter (M-102)MC-3
 - 3.1.4. Dynamic Set Point (R303)MC-3
 - 3.1.5. Excitation Mode (SW304).....MC-3
 - 3.1.6. Interlock (L301).....MC-4
 - 3.1.7. Dither - ON/ OFF (SW308)MC-4
 - 3.1.8. Static Set Point (R301)MC-4
 - 3.1.9. Static GainMC-4
 - 3.1.10. Load Cell.....MC-5
 - 3.1.1 1. Calibrate/ Operate (SW307)MC-5

- 3.1.12. Power (SW301)MC-5
- 3.1.13. PumpMC-6
 - 3.1.14. Dynamic Set Point (R303)MC-6
 - 3.1.15. Frequency Range - HIGH/ LOW (SW309).....MC-6
- 3.2. Rear Panel.....MC-6
 - 3.2.1. Exciter Head (J305).....MC-6
 - 3.2.2. Displacement (J311)MC-6
 - 3.2.3. Calibration Resistor (J304)MC-6
 - 3.2.4. Static Preload (SW310)MC-6
 - 3.2.5. Interlock (J306).....MC-7
 - 3.2.6. Power (J307)MC-7
 - 3.2.7. Fuse (F301)MC-7
 - 3.2.8. Program Input (J308).....MC-7
 - 3.2.9. Controlled Variable - StaticMC-8
 - 3.2.10. Controlled Variable - DynamicMC-8
 - 3.2.11. Compression Output (J310).....MC-9
 - 3.2.12. Standby Level (R313).....MC-9
 - 3.2.13. Load Cell Output (J303).....MC-9
 - 3.2.14. Power Amp - INT/ EXT (SW312)MC-9
 - 3.2.15. Power Amp - Input (J312).....MC-9
 - 3.2.16. EXT Set Point - Static (J313).....MC-10
 - 3.2.17. EXT Set Point - Dynamic (J314).....MC-11
- 4. Operation.....MC-11**
 - 4.1. Concept of Operation.....MC-11
 - 4.2. System InterconnectionMC-12
 - 4.3. Operation - Force ControlMC-12
 - 4.3.1. Set ControlsMC-12
 - 4.3.2. Depress the Power Switch.....MC-13
 - 4.3.3. Adjust Load Cell.....MC-13
 - 4.3.4. Depress Pump Start ButtonMC-13
 - 4.4. Operation - Displacement Control.....MC-14
 - 4.4.1. Set ControlsMC-14
 - 4.5. Operation - External VariableMC-15
 - 4.6. Computer Control - External Set Points (Static and Dynamic)MC-15
- 5. Theory of OperationMC-16**
 - 5.1. Circuit DescriptionsMC-16
 - 5.1.1. VR101 (Voltage Regulator).....MC-16
 - 5.1.2. SW310 (Preload Switch).....MC-16
 - 5.1.3. A109 (Amplif er).....MC-16
 - 5.1.4. A104 and A105 (Static Control Loop)MC-17
 - 5.1.5. A401 and A402 (Dynamic Loop).....MC-17
 - 5.1.6. A107 (Inverter Buffer)MC-18
 - 5.1.7. A106 and U103 (Peak Detector Circuit)MC-18

- 6. **Specifications** **MC-19**
- 7. **Drawings**..... **MC-19**
- 8. **Parts List** **MC-21**
- 9. **Calibration** **MC-26**
 - 9.1. Equipment Needed MC-26
 - 9.2. Master Controller MC-27
 - 9.2.1. Meter Zero Adjustments..... MC-27
 - 9.2.2. +/-15 Volt Supply Check MC-27
 - 9.2.3. +/- 60 Volt Supply Verif cation MC-28
 - 9.2.4. Load Cell Excitation Voltage Verif cation MC-28
 - 9.2.5. Master Controller Board 110-04 Calibration Procedure MC-28
 - 9.2.6. Master Controller Board 110-02 Calibration Procedure MC-31
 - 9.2.7. Master Controller Board 110-01 Calibration Procedure MC-31
 - 9.3. Exciter Head Calibration Procedure..... MC-38
 - 9.3.1. Load Cell Amplif er Calibration..... MC-38
 - 9.3.2. Static Loop Gain Calibration MC-40
 - 9.3.3. Static Set Point Level Calibration MC-42
 - 9.3.4. High Frequency Dynamic Level Calibration..... MC-42
 - 9.3.5. Low Frequency Dynamic Calibration MC-43
 - 9.4. Displacement Calibration Procedure MC-44
 - 9.4.1. LVDT Symmetry Verif cation and Adjustment MC-44
 - 9.4.2. Displacement Zero Calibration MC-45
 - 9.4.3. Displacement Scaling Calibration MC-45
 - 9.4.4. Final External Static Control Variable Calibration MC-45
 - 9.4.5. Dynamic Displacement Calibration..... MC-45
 - 9.4.6. External Static and Dynamic Set Point Calibration..... MC-46

1. Warranty

1.1. Xcite Products

Xcite Systems Corporation warrants that any Xcite manufactured product will conform to Xcite's written specifications applicable at the time of shipment and will be free from defects in material or workmanship for one year. During the Xcite warranty period, Xcite, or its agent, will repair or replace, at its option, any defective product when returned to the factory, freight prepaid by the buyer, and will return the product freight collect. Xcite assumes no liability for loss or damage during shipment to and from the factory. If insurance on the return shipment is required, it must be specified by the buyer.

1.2. Third Party Hardware Products

Xcite will transfer the original manufacturer's warranty for third party hardware (not manufactured by Xcite) to the buyer. The warranty policy of those companies in effect at the time of shipment will apply to their products, and Xcite assumes no additional responsibility. Xcite will indicate on its invoice the warranty terms relevant to specific Third Party Hardware items.

1.3. IMPORTANT LIMITATIONS

- 1.3.1.** The warranty period commences upon the day of shipment from Xcite without respect to any acceptance criteria or payment provisions in any particular contract.
- 1.3.2.** The warranty period does not apply to normal wear items or to damage caused by abuse, neglect or accident.
- 1.3.3.** Xcite's responsibility is limited to the above obligations, and Xcite cannot be held responsible for special or consequential or other damages.

ALL OTHER EXPRESS OR IMPLIED WARRANTIES, INCLUDING MERCHANTABILITY AND FITNESS FOR PURPOSE, ARE EXCLUDED.

1.4. NOTICE OF LIMITED WARRANTY

THE FOLLOWING ITEM(S) INCLUDED IN THIS XCITE PRODUCT OR SYSTEM ARE EXCLUDED FROM OUR ONE YEAR WARRANTY BECAUSE THEY ARE NORMAL WEAR ITEMS:

- 1) All system seals
- 2) Servovalve*

*The servovalve used on this system will be damaged if any particle(s) larger than 10 microns are permitted to enter the valve. Extreme care should be exercised when the hydraulic hoses are connected to ensure no foreign particles enter the connections. It is recommended to always wipe the hydraulic couplings with lint free towel before making connections. Always use the protective dust covers on the hoses (the dust covers can be connected together when operating the system). Any damage to the servovalve as a result of contamination is specifically excluded from warranty.

2. Receiving**2.1. Receiving Inspection Procedure**

Xcite Systems Corporation products are shipped in a manner designed to protect against all normal shipping hazards. Immediately upon receipt, inspect all equipment and note any visible damage. In accordance with the instructions in this manual, test its functional operation. Keep all documents in relation to this shipment. If shipping damage is apparent, file a claim with the carrier's claim agent and send a copy to Xcite Customer Service. Be sure to include the product name, model number and serial number on all correspondence.

2.2. Shipping Container

Shipping containers are supplied with all Xcite products. Store these containers and inserts in a dry area for possible later use.

Continuous Rotation Inertial Exciter System Setup and Operation

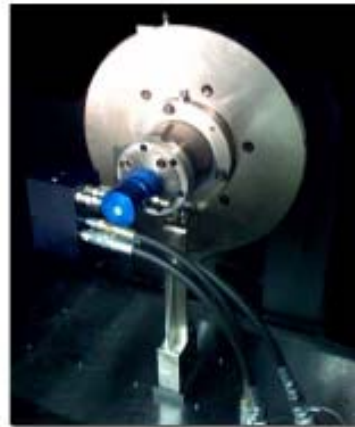

1. Introduction

The function of this system is to impart a controlled dynamic torque into a rotating structure such as a turbine rotor at rotating speeds of 400 to 7500 RPM. This torque generation is accomplished by a closed loop system which oscillates an inertial disk at frequencies independent of the rotational speed. Hydraulic pressure and flow is supplied by an Xcite 1201, 3000 psi and 1000 psi, 5 GPM air cooled power supply

2. System Description

The Xcite ES-320 Continuous Rotating Torsional Exciter consists of a limited rotation (+/- 12.5 degrees) hydraulic actuator whose body is attached to a mounting flange which is mounted to the structure under test. Alignment of this mounting flange with the turbine rotor is critical and is discussed later in detail. The rotor of the hydraulic unit is attached to an inertial disk which has 6 clearance slots for the mounting flange stand-offs. The radial acceleration of this inertial disk creates the inertial torque which is imparted to the rotating structure.

The relative positions of the hydraulic body and rotor are measured via tick pins. The time delay as the two tick pins pass two magnetic pickups is measured and converted to 0 to 25 degrees rotation by the Master Controller. Care must be exercised when mounting the magnetic pickup bracket. This is discussed later.

The dynamic differential pressure across the actuator vanes is measured via two piezoelectric pressure transducers and calibrated from the area of the vanes of the actuator for dynamic torque readout. Torque output is displayed by the controller with a range of 0 to 3,000 in-lb and an output sensitivity of 1000 in-lbs per volt.

The Xcite Master Controller provides closed loop control of the position of the disk when it is rotating by continuously comparing the angle feedback to the static setpoint. The Controller also provides compression amplitude control of the dynamic torque by monitoring the feedback torque and adjusting the drive signal to the control loop to maintain the dynamic setpoint level.

The figure below depicts the Xcite 1201B (DP) Hydraulic Power Supply connected via polarized quick disconnect hoses to the ES-320 Exciter Head servovalve. The 1201B (DP) Hydraulic Power Supply contains both 3000 psi pressure output and 1000 psi pressure output. Both outputs and the return flow line are connected to the Exciter Head servovalve as shown below. The 3000 psi connection is used for the pilot stage of the servovalve for better high frequency performance. The 1000 psi connector supplies the pressure and flow to the actuator for generating the dynamic torque.

System Block Diagram

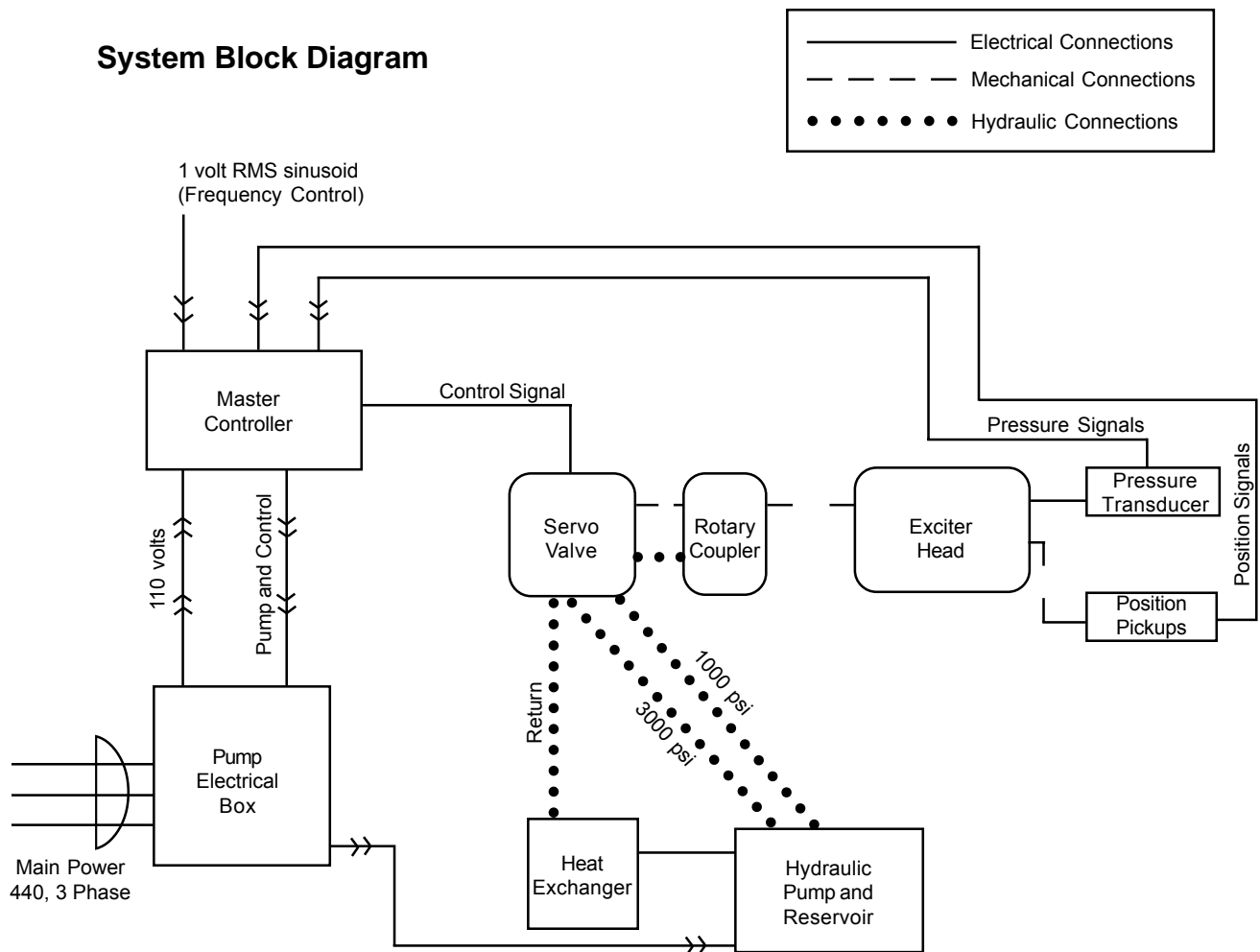

3. Setup Procedure

3.1. Mounting the ES-320 Exciter Head to the Test Structure

- 3.1.1.** The ES-320 must be aligned with the test structure within .001 inches. The ES-320 has an 11.0000 +0/-.0005 diameter mounting flange which must engage with a customer supplied mating flange with a recess of 11.0000 -0/+ .0005 inch diameter. The recess should be under cut to avoid binding. Set screws are provided on the mounting flange of the Exciter for alignment purposes and to facilitate exciter extraction.

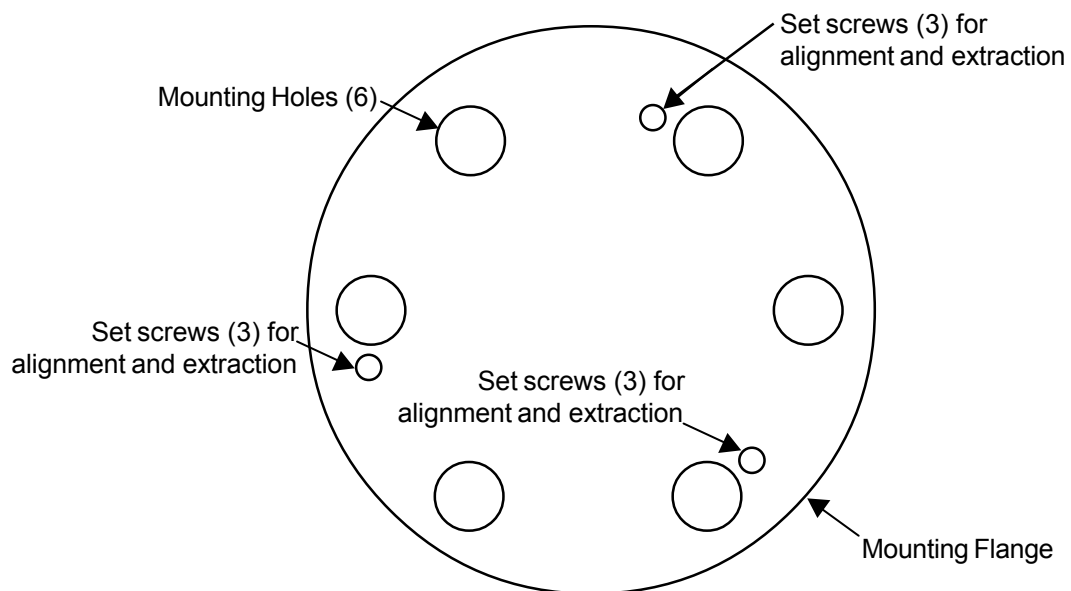

- 3.1.2.** Prior to mounting the ES-320, the mating flange must be measured to have a runout of no more than .001 inches.
- 3.1.3.** When mounting the Exciter, the six mounting bolts must be drawn into the mating flange evenly to assure perpendicularity with the structure axis.
- 3.1.4.** After mounting the Exciter, verify there is no more than .001 inches of runout at the servovalve end of the Exciter under slow roll conditions. (Use the three supplied set screws as jack screws to align to .001 inches of runout)
- 3.1.5.** Remove the lifting eye bolts from the large circular disk after securing the Exciter Head to the test structure.

3.2. Hydraulic Power Supply Commissioning Procedure

- 3.2.1.** Remove all packing material from inside and outside the pump cabinet.
- 3.2.2.** Locate the main power cable and attach it to the receptacle on the side of the Hydraulic Power Supply
- 3.2.3.** Fill oil reservoir with new clean Mobile DTE-24/25 hydraulic fluid (or equal). Check oil sight gage for proper oil level. (Approximately 20 gallons)
- 3.2.4.** Connect main power cable to main electrical service. Be sure that the proper voltage is applied to the Hydraulic Power Supply. The 3 phase wire colors are Red, Black and White. Ground (Green Wire) must be connected or ground loops will exist in instrumentation causing 60 Hz or 50 Hz signal noise.
- 3.2.5.** Connect the pump control cable (B-11921) to the Hydraulic Power Supply and to the rear panel connector of the Master Controller
- 3.2.6.** Turn on the Main Power Switch (large red/yellow switch) located on the front of the Hydraulic Power Supply
- 3.2.7.** Verify that the yellow *PHASE CORRECT* light is lit. If not, reverse the Red and Black wires at the main power connection. The pump will not start until the *PHASE CORRECT* lamp is illuminated.
- 3.2.8.** Connect one of the Exciter Head hoses to both the 1000 pressure out and return quick disconnects. This procedure effectively “short circuits” the output to the return and allows for all entrapped air in the pump to be removed on initial startup. Remove this connection after 5 to 10 minutes of running time.

3.3. Starting the Hydraulic Power Supply

- 3.3.1.** Check to see that the Red *EMERGENCY STOP BUTTON* located on the Power Supply is pulled out. The unit will not start if this switch is pushed into its *STOP MODE*.
- 3.3.2.** Push the Red *POWER* button on the Master Controller. It should light up along with the *PUMP STOP* light.

- 3.3.3.** Push the *PUMP START* button on the Master Controller and the Power Supply should start.
- 3.3.4.** Allow approximately 30 seconds for the pump to prime. There will be no pressure on the pressure gage because the supply and return are connected. (Section 3.2.8.) The pump will exhibit some loud noises as the entrapped air is purged. These noises will abate after 1 or 2 minutes of running time.
- After all priming noises have abated, shut off the pump and disconnect the “shorting” hose. Start the pump back up and it should come up to 1000 psi and 3000 psi on the gages. Some additional priming noise might last for 1 or 2 minutes and this is normal. After all priming noises have abated, the pump should be running smoothly at a pressure of 3000 - 3400 psi.
- 3.3.5.** For a 1201 Supply, which is air cooled, verify that the fan motor located in the Hydraulic Power Supply is operating.
- 3.3.6.** The Hydraulic Power Supply is now running correctly
- 3.3.7.** Push the *PUMP STOP* button. The power supply will shut down and the *PUMP STOP* switch will stay lit.
- 3.3.8.** Push the *POWER* switch of the Master Controller to turn it off.

3.4. Mounting the Magnetic Pickup Bracket

- 3.4.1.** The bracket must be rigidly mounted with the following clearances between faces of the pickups and the ends of the tick pins.
- Large Disk - Inertial Mass: 1/8 inch
Small Flange - Actuator Body: 1/8 inch
- 3.4.2.** Verify that a gap of approximately 1/8” is achieved between magnetic pins and pickups and that the tick pins do not hit the pickups.



- 3.4.3.** It is very important that the pickup transducers are mounted such that the metal tip in the end of the transducer is aligned as shown in the following drawing.

Color Dot on transducer **MUST** face to the side of the mounting bracket as shown below.

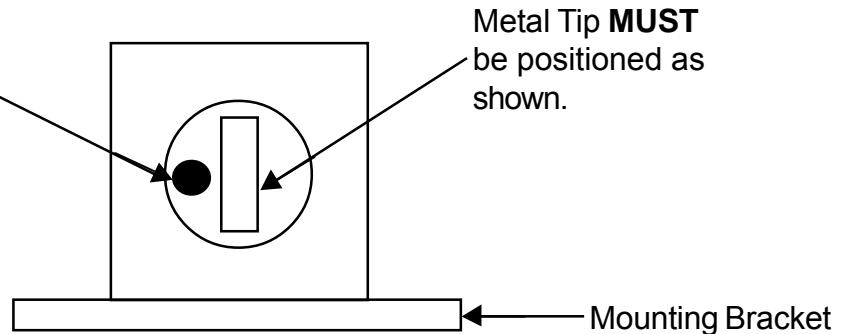

- 3.4.4.** Connect the cables marked P1 and P2 to the magnetic pickup transducers as outlined in Section 3.6.3. and accompanying drawing.

3.5. Hydraulic Hookup

- 3.5.1.** Connect the 1201B (DP) Hydraulic Power Supply 3000 psi pressure output via the polarized hose (smaller hose).
- 3.5.2.** Connect the 1201B (DP) Hydraulic Power Supply 1000 psi pressure output via the polarized hose.
- 3.5.3.** Connect the 1201B (DP) Hydraulic Power Supply return hose via the polarized hose.

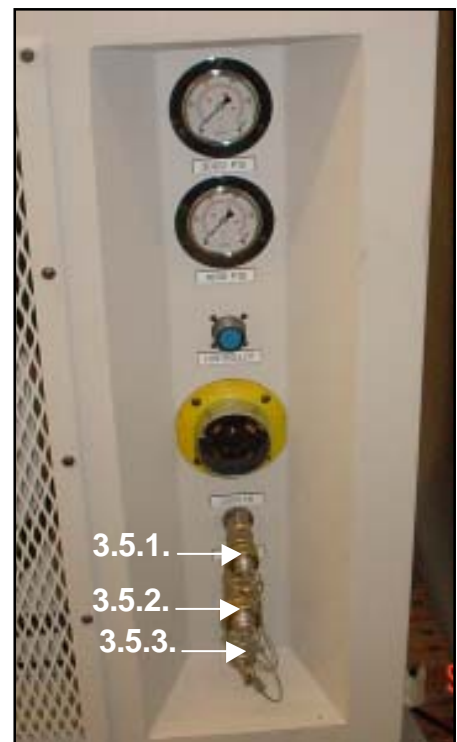

3.5.4. Take care to maintain cleanliness by always attaching caps to quick disconnects when disconnected.

3.5.5. When in doubt about hose polarity the convention is:

Supply Pressure - Coupler (Both 1000 and 3000)

Supply Return - Nipple

3.5.6. Take care that hoses are not going to rub against sharp object when pulsating.

3.6. Cable Hookup

3.6.1. Connect the Pump Control Cable B-11921 to the Controller J307 and to Pump J501.

3.6.2. Connect Head Control Cable B-12101-01 to Controller J305 and to the servovalve and pressure transducers (J4 and J5).

3.6.3. Determine which direction the turbine rotor will run and connect the Displacement Control Cable to Controller J311 and J309 and magnetic pickups P1 and P2.

NOTE 1: Rotation convention for the ES-320 Exciter is defined as clockwise (CW) when viewing the rotation of the inertial disk from the servovalve end of the Exciter. Counter clockwise (CCW) is the opposite direction when viewed from the servovalve end of the Exciter.

NOTE 2: Never switch the BNC cables going to P1 and P2. The connectors which plug into the magnetic pickups are wired differently and must be reversed at the magnetic pickup when changing from CCW to CW rotation.

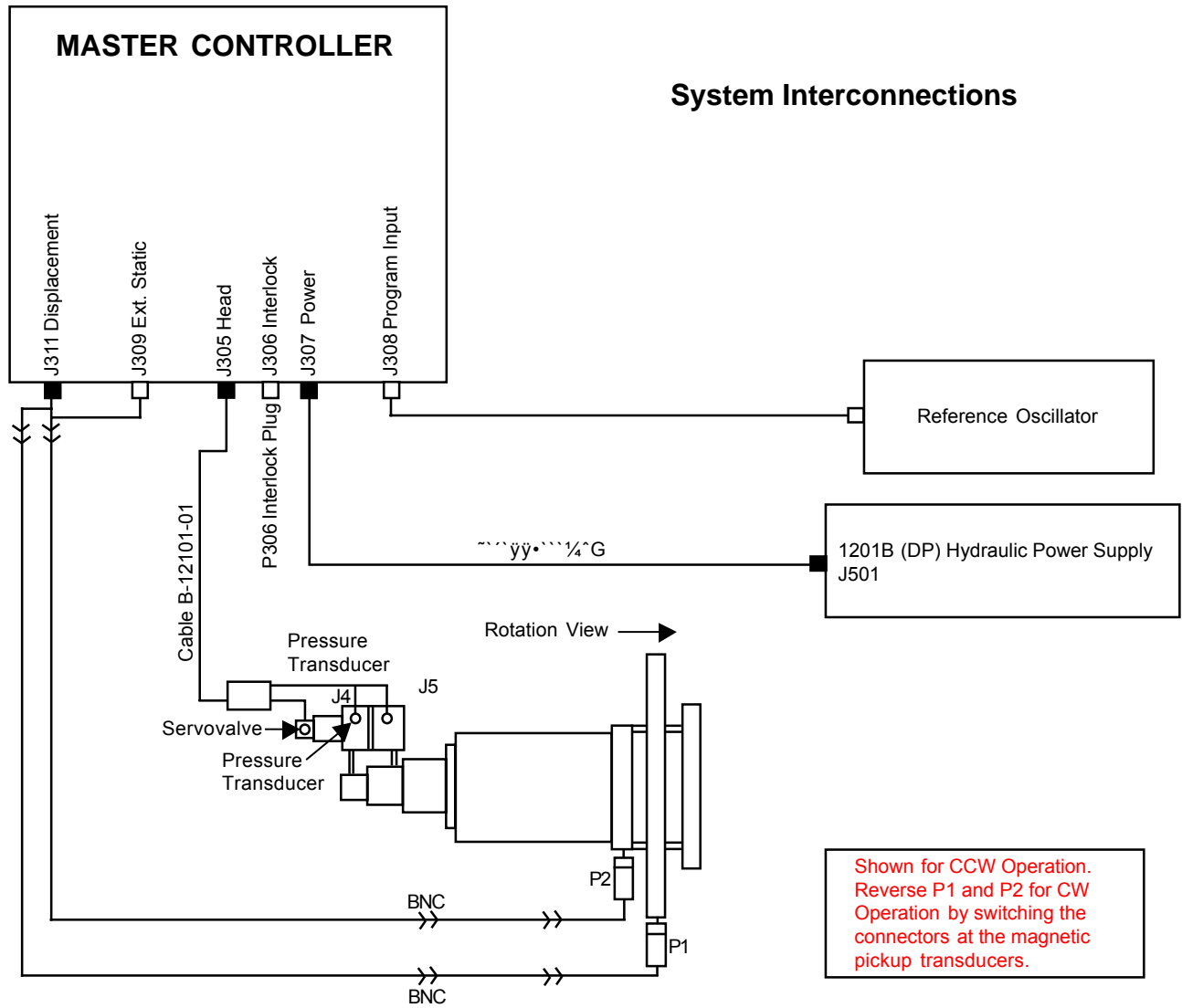

4. Operation Procedure

4.1. Switch Settings

- 4.1.1. Set the switches on the back of the Master Controller to the following:

CONTROLLED VARIABLE	EXTERNAL
STATIC	(Static Displacement Control)
DYNAMIC	INTERNAL
STATIC PRELOAD	COMPRESSION
POWER AMP	INT

- 4.1.2. Set the switches on the front of the Master Controller to the following:

DITHER	OFF
STATIC SETPOINT	5.0
STATIC GAIN	FIXED
	(For Displacement Control of Inertial Mass)
VARIABLE GAIN	10.0
LOAD CELL	OPERATE
EXCITATION MODE	STANDBY/ RESET
FREQUENCY	HIGH
DYNAMIC SETPOINT	0.0

- 4.1.3. Connect a 1.0 Vrms variable frequency oscillator to the Program Input J308. (1 Hz to 2000 Hz)
- 4.1.4. Turn on 3 phase power to the 1201B (DP) Hydraulic Power Supply and assure proper phase connection to voltage supply.
- 4.1.5. Press *POWER* on Master Controller. The *POWER* light will be illuminated.
- 4.1.6. Press *PUMP START* on the Master Controller.
- 4.1.7. Assure that the meters of the 1201B (DP) read 1000 psi and 3000 psi.

- 4.1.8. Begin Rotation of the test structure.

CAUTION: The hydraulic union on the Exciter Head requires lubrication from the hydraulic oil when rotating. Do not rotate the test structure without the Hydraulic Power Supply being turned on!

- 4.1.9. When the test structure speed reaches approximately 400 RPM the *STATIC SIGNAL METER* will move to 50% from full scale. This indicates that the static control loop has locked on to the inertial disk position and is maintaining it at midstroke in the *STANDBY* position.

- 4.1.10. Turn the *EXCITATION MODE* to *STATIC*. The *STATIC SIGNAL LEVEL* should remain at 50% since the *STATIC SETPOINT* is set to 5.0. If necessary make adjustments to the *SETPOINT* such that the meter is reading 50% to assure that the inertial disk remains at midstroke.

- 4.1.11. Turn *EXCITATION MODE* to *STATIC + DYNAMIC*.

- 4.1.12. Slowly increase the *DYNAMIC SETPOINT* until the desired torque is monitored at the *DYNAMIC SIGNAL LEVEL* meter and is measured at the *LOAD CELL OUTPUT BNC*. The output voltage calibration is 1000 in-lb/volt. Figure 3 depicts the Dynamic Torque of the Exciter Head as a function of frequency

NOTE: It is normal for the static position meter reading to vary slightly around the 50% setting during frequency sweeps - variation is proportional to sweep speed.

5. Shutdown Procedures

- 5.1. Turn *EXCITATION MODE* to *STANDBY/ RESET*.

- 5.2. Stop rotation of test structure.

NOTE: At approximately 400 RPM the static loop will lose control and the inertial disk will move to one of its stops.

- 5.3. Push *PUMP STOP* after the Exciter has stopped rotating.

6. Troubleshooting Guide

Problem	Action
Static meter does not indicate mass has moved to mid position when system is turned on in Standby/ Reset mode.	Check that the Hydraulic Power Supply is turned on and reading 1000 & 3000 psi. See 4.1.8.
	Check that all hoses and cables are connected. See 3.3. and 3.4.
	Check that P1 and P2 are connected correctly. P1 is reading the position of the large disk and P2 is reading the position of the small disk on the rotor actuator if the Exciter is rotating CCW when viewed from the servovalve. If the Exciter is rotating CW, reverse the above connections. See 3.6.3.
	Verify that all Master Controller switches are in the correct position. See 4.1.1. and 4.1.2.
	Verify that the Exciter is rotating at 400 RPM minimum. See 4.1.9.
Static meter does not remain at 50% indicating that the mass is remaining at midstroke when the mode switch is moved to Static.	Adjust the Static Setpoint pot so the meter is reading 50%. See 4.1.10.
No torque is measured at the Force Output BNC or is indicated on the Dynamic meter.	Verify that the 1Vrms signal from the signal source is connected to the Program Input BNC on the back of the Master Controller.
	Verify that Connectors J4 and J5 are correctly attached to the pressure transducers. See 3.6.
	Verify that the Dynamic Setpoint pot is turned up. See 4.1.12.

ES-320 Exciter Head

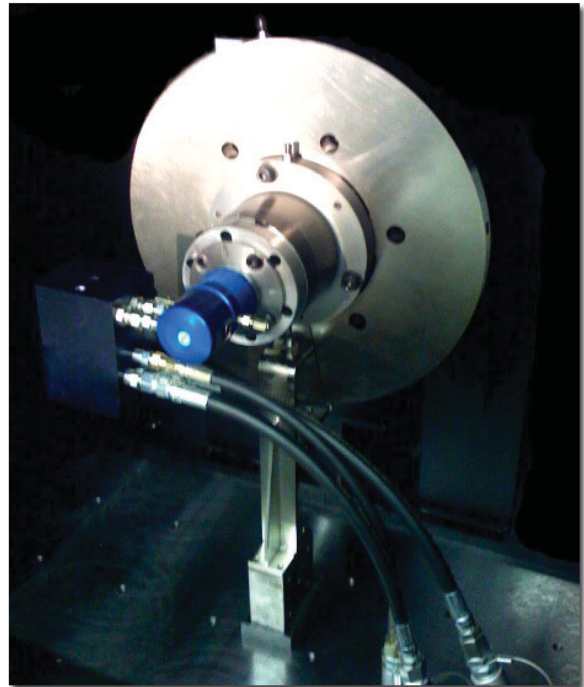

Continuous Rotating Torsional Excitation System Head

1. Introduction

The ES-320 Exciter Head is capable of introducing a variable dynamic torque into a rotating test specimen. The dynamic torque is generated by accelerating a 80 lb (approximate weight) circular steel mass within a travel limit of +/- 12.5 degrees.

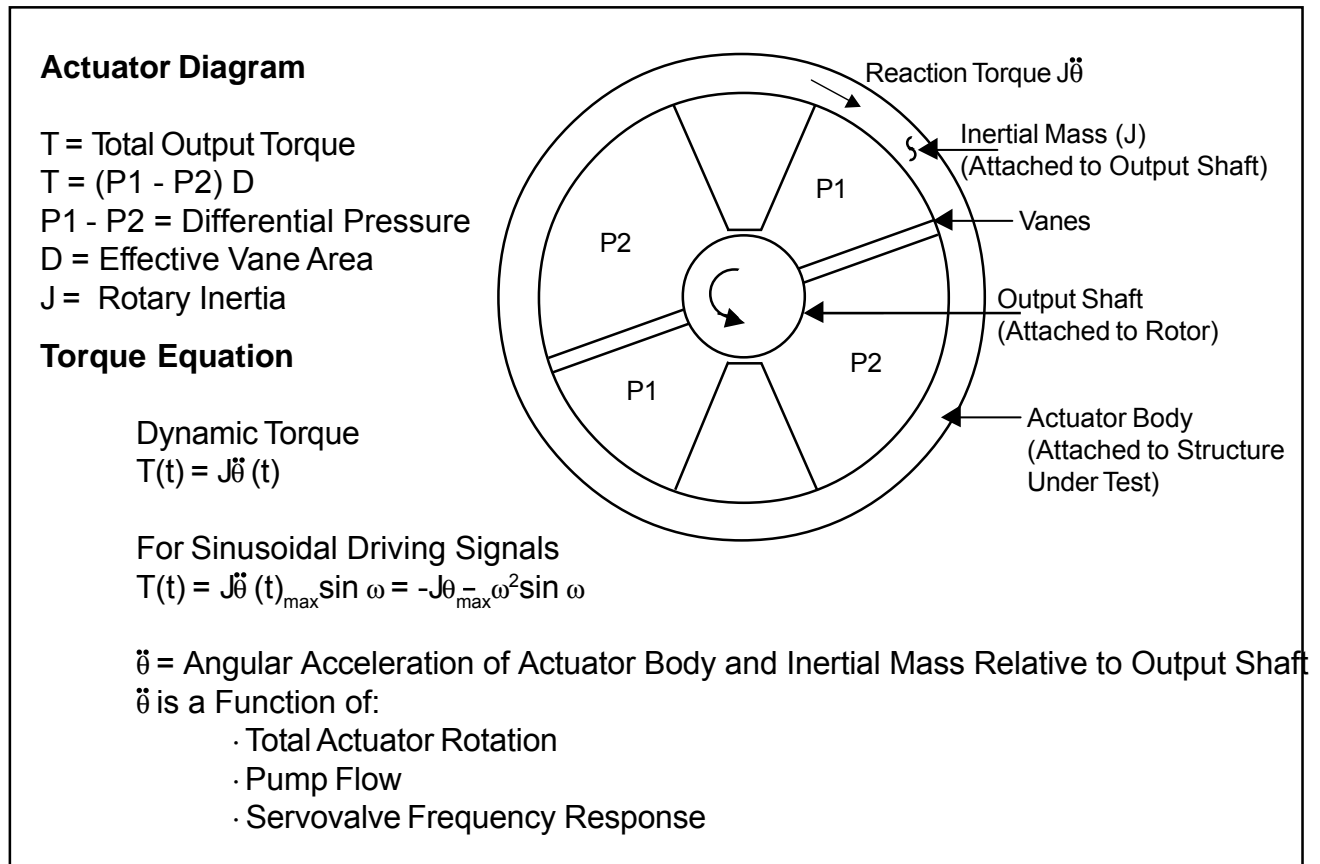

A special servovalve is employed which uses 3000 psi for the first stage of the servovalve. This in turn controls a 1000 psi source across the actuator vanes. The higher first stage pressure maintains the high frequency response of the servovalve. The second stage pressure is limited to 1000 psi to prevent damage to the Exciter Head or hydraulic coupling.

Continual rotation of the Exciter Head is accomplished by using a rotating union to connect the two control port outputs of the servovalve to the input ports of the actuator.

Two pressure transducers are used to monitor the pressure at the servovalve control ports and the difference of these two pressures is used to produce a dynamic feedback signal.

Phase position is derived from two magnetic pick ups which detect steel tick pins extending from the actuator body and the circular mass.

2. System Components

The ES-320 ROT actuator consists of the components listed below:

2.1. Actuator

The actuator is a dual vaned unit capable of developing +/-4250 in-lbs of torque.

2.2. Rotating Union

A hydraulic union which allows the two control ports of the servovalve to be connected to the rotating actuator.

2.3. Pressure Transducer - PC Model 101A04

This is a quartz pressure transducer with a built-in amplifier. These units are used to measure the dynamic pressure of each of the servovalve control ports. (See enclosed calibration curves at the end of this section.)

2.4. Magnetic Pick-Ups - Air Pax Model 1-0054

A high output unit used to detect the position of the actuator body and the inertial mass.

2.5. Servovalve - Moog Model 760A-728

A proportional flow control device which controls the hydraulic flow across the actuator.

3. Specifications

Maximum Rotation Speed	7500 RPM
Minimum Speed for Control Loop Stability	400 RPM
Static Feedback	Via Tick Pins (Angle)
Dynamic Feedback	Via Pressure Transducers (Torque)
Servovalve	Multi-stage 5 GPM
Inertial Disk Diameter	18 in
Inertial Disk Weight	80 lbs
Dynamic Inertial Torque	1000 in-lb to 3000 in-lb from 10 Hz to 200 Hz (Independent of Speed)
Weight	130 lbs

4. Head Operating Instructions

All operations of the Exciter Head are controlled by the Xcite Master Controller. Please refer to the Master Controller section for proper use of the system.

5. Drawings

All operations of the Exciter Head are controlled by the Xcite Master Controller. Please refer to the Master Controller section for proper use of the system.

- 5.1. Dimensional Drawing for ES-320 Exciter Head
 - Outline Drawing D-30131-0
 - Mounting Flange Detail D-14689-3
 - Mounting Bracket Detail..... D-30132-0
- 5.2. Pressure Gage Calibration Curves
- 5.3. Torque (in-lb) vs Frequency for ES-320 Exciter Head
- 5.4. Master Controller Output Sensitivities:
Torque Output: 1000 in-lb/volt

Peak Dynamic Torque vs. Frequency

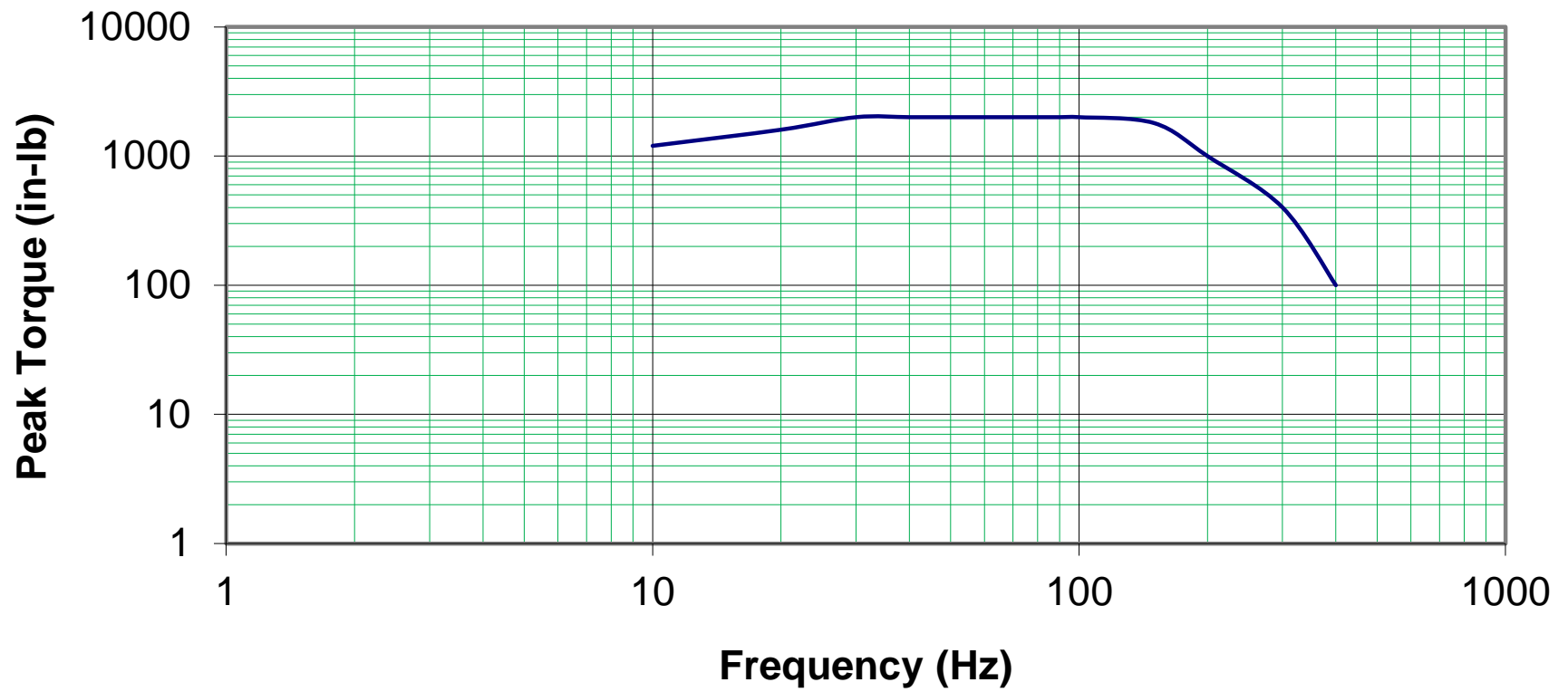

1201B Dual Pressure Hydraulic Power Supply



1. Introduction

The XCITE Hydraulic Power Supplies are designed to fulfill the power requirements of exciter heads using the most energy-efficient and maintenance free components available. All units use a highly reliable, variable volume, pressure compensated, axial-piston pump to deliver only the energy demanded by the load, thus reducing power consumption.

The 1201B (DP) is a special adaptation of the standard 1201B Hydraulic Power Supply. The 1201B (DP) is a dual pressure supply specifically designed for the ES-315 Rotational Exciter Head. The 1201B (DP) Supply has both 3000 psi pressure output and 1000 psi pressure output. Both pressure outputs are available on the side of the Hydraulic Power Supply and have separate pressure gauges to read the two pressures.

2. Commissioning Procedure

2.1. Initial Setup of Hydraulic Power Supply is as follows:

- 2.1.1. Remove all packing material from inside and outside the pump cabinet.
- 2.1.2. Remove the main power cable from inside of cabinet.
- 2.1.3. Fill oil reservoir with 20 gallons of new, clean Mobile DTE-24/25 hydraulic fluid (or equal) (See drawing B-30070, item 3 for location of filler cap). Check oil sight gage for proper oil level.
- 2.1.4. Connect one of the exciter head hoses to both the 1000 psi pressure out and return quick disconnects. This procedure effectively "short circuits" the output to the return and allows for all entrapped air in the pump to be removed on initial startup. Remove this connection after 5 to 10 minutes of running time.
- 2.1.5. Connect main power cable to main electrical service. The 1201B Hydraulic Power Supply is wired for 440V, 60Hz 3-phase mains. The 3-phase wire colors are Red, Black and White. Ground (Green Wire) must be connected or ground loops will exist in instrumentation causing 60Hz or 50Hz signal noise.
- 2.1.6. Connect the 1104-MOD-ROT pump control cable (B-11921) to the Hydraulic Power Supply and to the rear panel connector of the Master Controller.

- 2.1.7. Turn on the Main Power Switch (large red switch) located on the Hydraulic Power Supply.
- 2.1.8. Verify that the yellow *PHASE CORRECT* light is lit. If not, reverse the Red and Black wires at the main power connection. The pump will not start until the *PHASE CORRECT* lamp is illuminated.

2.2. Starting the Hydraulic Power Supply

- 2.2.1. Check to see that the Red *EMERGENCY STOP BUTTON* located on the Power Supply is pulled out. The unit will not start if this switch is pushed into its *STOP MODE*.
- 2.2.2. Push the Red *POWER* button on the Master Controller. It should light up along with the *PUMP STOP* light.
- 2.2.3. Push the *PUMP START* button on the Master Controller and the Power Supply should start up. The *GREEN* voltage applied light should be illuminated at this time. (Pump pressure will be *ZERO* due to the short circuit hose). After 5 to 10 minutes, shut down the pump. **See 2.1.4.**
- 2.2.4. Remove the hose connecting the pressure out to the return. Restart the Power Supply. Allow approximately 30 seconds for the pump to prime and come up to 3000 psi. Check the pressure 3 on the gages located on the side of the Hydraulic Power Supply. They should read approximately 3000 psi and 1000 psi.
- 2.2.5. Verify that the fan motor located in the Hydraulic Power Supply is operating.
- 2.2.6. The 1201B Hydraulic Power Supply is now running correctly.
- 2.2.7. Push the *PUMP STOP* button. The Power Supply will shut down and the *PUMP STOP* switch will stay lit.
- 2.2.8. Push the *POWER* switch of the Master Controller to turn it off.

2.3. Hydraulic Hookup

- 2.3.1.** Connect the Hydraulic Power Supply pressure and return hoses to the Exciter Head 1000 psi pressure and 1000 psi hoses via the polarized quick disconnects supplied with the system hoses. Connect the smaller 3000 psi pressure hose to the corresponding 3000 psi supply port.
- 2.3.2.** Take care to maintain cleanliness by always attaching caps to the quick disconnects when disconnected.
- 2.3.3.** When in doubt about hose polarity, the convention is:
- Supply Pressure - Coupler (Both 3000 and 1000 psi)
Supply Return - Nipple
- 2.3.4.** Take care that hoses will not rub against sharp objects when pulsating.

3. Theory of Operation

The purpose of the XCITE Hydraulic Power Supply is to supply clean hydraulic oil at a constant pressure under the varying flow demands of the force exciter head. The system was designed to do this in the most efficient manner, considering power requirements, reliability, safety, ease of maintenance, and operator convenience.

3.1. Circuit Description (Hydraulic)

An oil reservoir provides storage for all necessary supply oil and provides some oil cooling. (See Drawing B-30070 and B-30071) Mounted on the reservoir are oil level and oil temperature gauges, a temperature sensitive switch, and a reservoir fluid level detector switch for motor shut down. The 3000 psi pressure is achieved by a variable volume, pressure-compensated pump that has a factory set delivery rate. The 1000 psi pressure is achieved by a pressure reducing valve (Item # 44 on B-30071) which is connected to the 3000 psi supply and set for 1000 psi pressure.

Fluid from the pump first passes through a three-micron (absolute) filter. Should this filter become clogged, a pressure drop builds up across the sensor, causing a switch to trip. This causes the *FILTER* light to illuminate. The system should not be operated until the filter element is changed. After passing through the filter, oil flows to the pressure output disconnect.

3.2. Circuit Description (Electric)

The electrical input is wired for 440V, 60Hz (See drawing B-30072). The fourth wire (green) is a ground wire and must be tied to earth ground to prevent floating grounds due to an unbalanced load.

The pump motor uses the high voltage 3-phase power, while the remaining loads derive 120 volt, single-phase from the step-down Transformer T-1 (designated 14), appropriately connected to the incoming power to provide 120 VAC on the secondary of the transformer.

Two-way protection of the three-phase power is provided. A magnetic circuit protector provides over current protection. It is also connected to the electrical box operating handle to disconnect power in the electrical box.

Pump motor overload protection is provided by thermal overload heaters in the motor starter, which were specifically designed for the pump motor. A *RESET* button is conveniently located inside the electrical box, should be thermal overload trip. The pump start relay, 1CR, (designated 5), is a latch-up design so that momentary switches may be used for pump start and pump stop operations.

A phase sequence relay 1PM (designated 1) is connected to and monitors the 3-phase incoming line to determine if the phasing is connected correctly to provide proper motor rotation. If the *START* light is off, any two legs of the incoming lines should be reversed.

If the phase is incorrect, 1PM (1) remains de-energized, thus preventing the system from being energized. If the phasing is correct, 1PM (1) energizes, allowing 120 VAC from T-1 (14) to be applied to the pump unit.

The T-1 (14) Transformer is fused by 4FU and 5FU. The system *POWER* switch connects power to the control circuits. If oil temperature is normal, relay 2CR (designated 10) is not energized. Momentarily, pressing the *START* button will energize 1CR (designated 5) if oil level, temperature, filter, and pressure selection are correct.

Relay 1CR (5) energizes the motor starter 1M. Auxiliary contact 1M closes, latching 1CR. A normally closed CR1(5) contact opens, turning off the *STOP* light.

Momentarily pressing the *STOP* button breaks the latch-up circuit and de-energize 1CR (5) and the pressure relief solenoid. After a short delay, an *OFF DELAY* contact on 1CR opens, de-energizing the motor-starter coil and causing the pump to stop.

Relay 2CR (10) is normally not energized unless the oil temperature exceeds 160 degrees F. If the *RED OIL OVERTEMP* is illuminated, the system must be reset by pushing the pump *STOP BUTTON* on the Master Controller after the system cools down.

If the differential pressure drop across the filter exceeds approximately 50 psi, the *RED FILTER* restriction light will illuminate. The Power Supply will **NOT** shut off, however the filter should be changed when the filter light is illuminated.

4. Description

Included on the hydraulic power supply are two oil supply line pressure gauges and a timer which records pump running time. Mounted on the side of the reservoir is an oil level sight gauge with an integral oil temperature thermometer. A reservoir drain is also located on the reservoir. All motor controls and associated electrical equipment are located in the electrical control box. Connections for pressure and return hoses are attached with quick disconnect style connectors.

4.1. Major Components

- Oil Reservoir
- Motor
- Variable volume pressure-compensated Pump
- Three-micron Filter Assembly
- Heat Exchanger
- Motor Control Box
- Hydraulic Hoses

4.2. Control Components

4.2.1. Emergency Stop Switch

This switch de-energizes the motor-starter relay, bypassing all shutdown logic; thus causing the motor to stop. Use it only in an emergency situation.

WARNING

Some operating conditions cause the system to shutdown.

4.3. Monitoring Devices

4.3.1. Phase Sequence Relay (PHASE Indicator)

A phase sequence relay monitors the 3-phase power applied to the unit. If the phasing of the wires is incorrect, the relay will prevent the pump from being energized, and the *PHASE CORRECT* lamp will not illuminate.

4.3.2. Filter Pressure Drop Sensor (FILTER Indicator)

This sensor sends a signal if the differential pressure across the filter element is excessive. This occurs when the differential pressure drop across the replaceable filter element exceeds 50 psi. Excessive differential pressure occurs when the filter element is clogging, fluid viscosity is too high, fluid temperature is too low, or any combination. At that time, the *FILTER* light illuminates.

Note: There may be times when the system is first started and the oil is cold that the filter light will illuminate. Allow 10 to 20 minutes of operation and if the filter light goes off, then the filter is not dirty and does not need replaced.

4.3.3. OIL OVERTEMP Indicator

The temperature sensor monitors the oil temperature of the reservoir and prevents the pump from running if the oil temperature exceeds 160 degrees F. The *OIL OVERTEMP* light illuminates, indicating that the maximum allowable oil temperature has been exceeded.

4.3.4. LOW OIL Indicator

The level sensor monitors the oil level in the oil reservoir and prevents the pump from running if the oil level is low. The pump will shut down or fail to start until additional oil is added. The red *LOW OIL* indicator lamp illuminates during this condition.

4.3.5. Voltage Applied Indicator

A green light indicating power is switched onto the pump motor. The light will ONLY illuminate after depressing the *PUMP START* button on the Master Controller.

5. Care and Maintenance

WARNING

Electrocution or severe electrical shock may occur.

When the MAIN power is plugged in, the line side of the motor starter is at line voltage.

The XCITE Hydraulic Power Supply was designed so that no periodic lubrication on mechanical parts is required. Cleanliness is very important when using sophisticated hydraulic systems, and although a clean room environment is far from necessary, general cleanliness is recommended. Routine maintenance on the overall system should include the following.

5.1. Operating Care

- 5.1.1. Wipe off all cables after each use.
- 5.1.2. Never drag cables across the floor.
- 5.1.3. Immediately after the hydraulic hoses are disconnected, cover all hydraulic connectors with the covers provided.
- 5.1.4. During operation, the oil temperature should never rise above 160 degrees F. (The oil temperature thermal relay shuts down the system at 160 degrees F.)
- 5.1.5. Before each test, check the oil pressures to make sure they are at 3000 psi and 1000 psi. A flow screw adjustment is located on the top of the pump compensator assembly. This control is preset at the factory and should not be adjusted (slotted screw with locknut).
- 5.1.6. Before each test, check to make sure that the air heat exchanger blower is operational, that pump maintenance warning lights are not illuminated, and that the phase sequence indicator show proper motor phasing.

If for some reason the system has overloaded, the pump motor started thermal overload will trip. Reset it by opening the access door, and pushing the reset button located on the motor starter.

5.2. Maintenance

- 5.2.1.** To keep the system operating within the specified limits, it is necessary to periodically check the oil level by observing the oil level gauge. Fluid should fill the gauge.
- 5.2.2.** Oil should be changed after every 1000 hours of pump operation.
- 5.2.3.** The condition of the filter is displayed by the light on the electrical control box inside the cabinet. The filter requires replacement only when the *FILTER* light is illuminated.

WARNING

All oil should be completely drained from the reservoir during transportation. (See drawing B-30070, item 35 for location of reservoir drain hose)

6. Troubleshooting

Listed below are some of the common problems which may be experienced with a Power Supply.

6.1. Unit Overheats

Overheating may be caused by a clogged heat exchanger, restricted air flow, malfunction of the check valves, or failure of the heat exchanger fan.

The efficiency of an oil/ air heat exchanger decreases as the ambient temperature increases. The maximum ambient temperature at which the heat exchange can effectively maintain the oil temperature below 160 degrees F is approximately 100 degrees F. If continuous operation in ambient temperature above 100 degrees F is desired, it is recommended that an oil/ water heat exchanger be added externally to cool the return line oil before it is returned to the oil reservoir.

6.2. Pump de-energizes

The pump de-energizing for no apparent reason can be caused by a noisy 3-phase power line where the 3-phase voltage drops below the rated voltage for more than 10 milliseconds. This results in the phase monitor relay 1PM momentarily de-energizing, shutting off the system.

7. Specifications

<u>Item</u>	<u>Specifications</u>
Dimensions	
Height	54.50"
Width	38.13"
Depth	30.13"
Weight	863 lb (without oil)
Hydraulic Oil	20 gallons of Mobil DTE-24/25
Pump	5 GPM
Pressure-compensated variable flow axial piston	
Motor, 440V - 60Hz	10 HP
Reservoir	20 gallon
Cooling	Air (Maximum ambient room temperature 100 degrees F)

8. Drawings***Model 1201B Dual Pressure***

Outline Dimensions	B-30069
Pump/ Reservoir	B-30070
Hydraulic Schematic	B-30071
Electrical Schematic	B-30072
Electrical Box Layout	B-30073

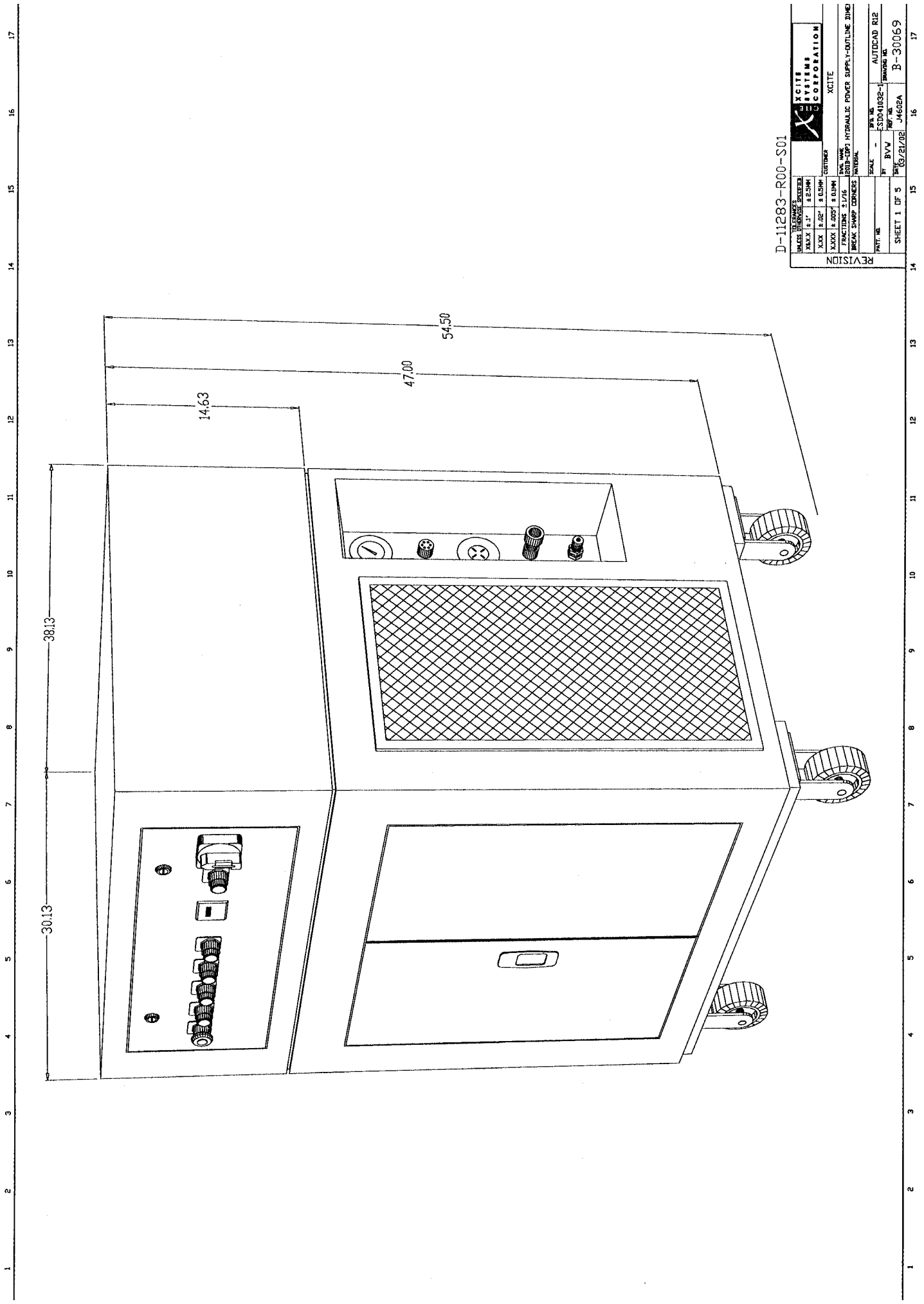

D-11283-R00-S01

MAX. WEIGHT	8.25MM
MAX. SIZE	8.25MM
MAX. LENGTH	8.25MM
MAX. WIDTH	8.25MM
MAX. HEIGHT	8.25MM
MAX. DIAMETER	8.25MM
MAX. THICKNESS	8.25MM
MAX. WEIGHT	8.25MM
MAX. SIZE	8.25MM
MAX. LENGTH	8.25MM
MAX. WIDTH	8.25MM
MAX. HEIGHT	8.25MM
MAX. DIAMETER	8.25MM
MAX. THICKNESS	8.25MM
SCALE: 1" = 1" (1:1) DATE: 03/21/02 DRAWN BY: BVV CHECKED BY: JAGGA MATERIAL: ALUMINUM FINISH: ANODIZED PART NO: SDD01032-1 REV: 01 AUTOCAD R12 SHEET 1 OF 5 J4602A B-30069	

REVISION

1100, 1200 and 1300 Master Controller



1. Introduction

The Xcite Master Controller is a compact electronics control package designed to provide all the controls and displays necessary to operate an Xcite exciter system. The latest concepts in electronic design, including plug-in printed circuit boards, flexible systems interface and easy-to-use operator controls, are incorporated in the unit.

The Master Controller represents the heart of the closed loop hydraulic exciter system. It enables two variables to be independently controlled simultaneously via the Static Level and Dynamic Level controls. It incorporates automatic gain control in the dynamic loop which allows a constant amplitude of the dynamic variable to be maintained even as the reference frequency of excitation is changed.

2. Theory of Operation

The major design concept used in the Xcite Master Controller is one of providing accurate feedback control of an exciter head's capability, such as force, displacement, velocity, acceleration, etc.

The Master Controller senses the feedback signals from the appropriate transducers and provides an output drive signal to the exciter head servovalve which will cause the exciter to maintain the desired levels of the static and dynamic variable as determined by the dynamic and static level controls.

2.1. Configurations

The master controller can be operated in either a single- or dual-loop configuration.

2.1.1. Single Loop

Single-loop operation is selected by placing the Frequency Range switch to the *LOW* position. This mode is generally used to control a single variable, usually force or displacement. In this *LOW FREQUENCY* mode of operation, a dynamic signal is generated by summing the reference frequency present at the *PROGRAM INPUT* with the Static Level set point signal.

2.1.2. Dual Loop

Dual-loop operation is selected by placing the *FREQUENCY RANGE* switch to the *HIGH* position. This mode applies the dynamic feedback signal to the dynamic control loop which incorporates an automatic gain control circuit. This allows a desired dynamic amplitude variable to be set and maintained over a broad frequency range and structure stiffnesses.

3. Description

The Xcite Master Controller (Model 1104, 1204 and 1304) has a variety of inputs and switch selectors which allows the various operational modes of the Exciter Head. Listed below is a description of each connector, switch and indicator located on the Master Controller.

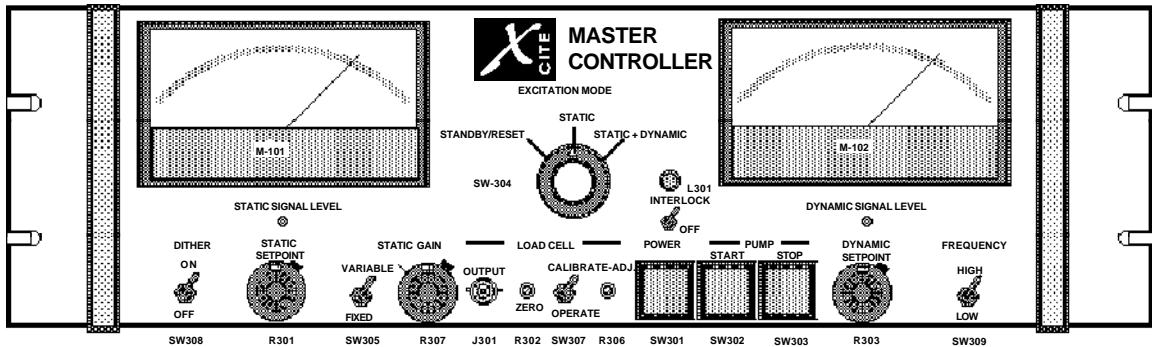

Front Panel

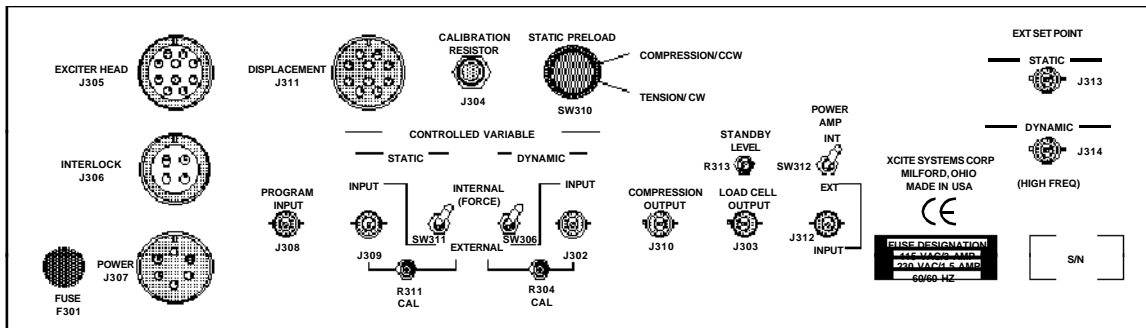

MASTER CONTROLLER REAR PANEL (OUTSIDE VIEW)

Outside Rear Panel

3.1. Front Panel (Left and Right Top Section)

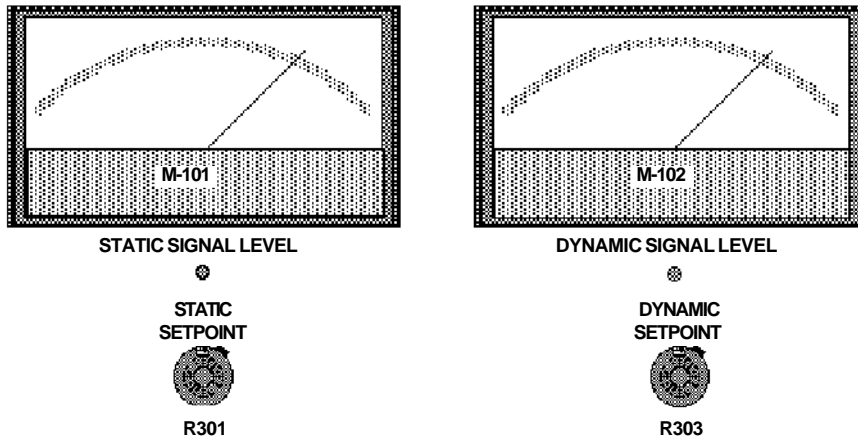

3.1.1. Static Signal Level Meter (M-101)

The Static Signal Level is displayed on this meter in Static Force Pounds or Static Displacement.

3.1.2. Static Set Point (R301)

Potentiometer used to set value of desired static variable. The Static Set Point potentiometer is calibrated in percent full scale.

3.1.3. Dynamic Signal Level Meter (M-102)

The Dynamic Signal Level is displayed on this meter in Peak Dynamic Force Pounds.

3.1.4. Dynamic Set Point (R303)

Potentiometer used to set value of desired dynamic variable. The Dynamic Set Point potentiometer is calibrated in Peak Dynamic Force Pounds.

3.1.5. Excitation Mode (SW304)

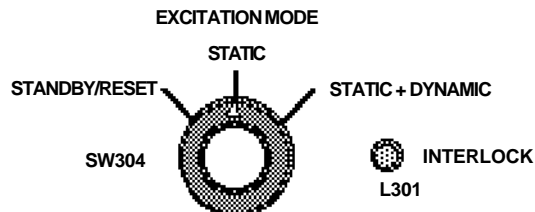

Used to select operating mode of exciter head. Turn the switch so that the arrow points to the mode of interest.

Standby/ Reset

Exciter head is at (or returns to) standby position, as preset by set-screw potentiometer on rear of Master Controller. The interlock circuits are also reset in this mode.

Static

Only the static control loop is activated.

Static + Dynamic

The static and dynamic control loops are activated.

3.1.6. Interlock Selector Switch (Optional) and Light 301

The Interlock Selector Switch (provided only on Master Controllers operating torsional Exciter Heads) located directly below the red Interlock Light is used to disable the Interlock system when in the *STATIC MODE* position. Normal Interlock occurs when the switch is in the *UP* position. Disabled Interlock occurs when the switch is in the *DOWN* position.

The Interlock Light indicates when interlock circuits are activated, causing exciter head to return to standby position. Excitation mode control switch must be moved to Reset position to continue operation.

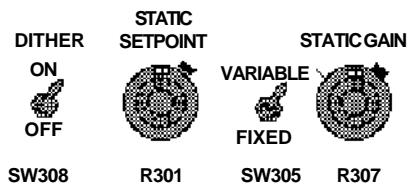
3.1.7. Dither - ON/ OFF (SW308)

Front Panel (Left) - Bottom Section

Toggle switch which, when in *ON* position, provides 400 Hz signal to exciter servovalve. It is used primarily to overcome exciter stiction at low frequencies of operation. (Below 5 Hz)

3.1.8. Static Set Point (R301)

Indicates desired static level. Calibrated in percent full scale. **See 3.1.2.**

3.1.9. Static Gain**Static Gain - Variable/ Fixed (SW305)**

Toggle switch. In *VARIABLE* position actuates loop static gain potentiometer (R307).

Static Gain (R307)

Potentiometer used to set static control loop gain based on the stiffness of the structure under test. Used to eliminate control loop instabilities when using exciter in Static Displacement Mode on a weak structure.

3.1.10. Load Cell

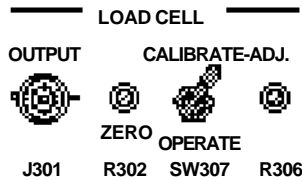

Front Panel (Middle) - Bottom Section

Output (J301)

BNC connector providing load cell output signal for monitoring of the force signal (varies from -10V to +10V depending on the actual value of the force). Duplicated on back of controller.

Zero (R302)

Set screw potentiometer used to zero the load cell output when there is no load applied.

3.1.11. Calibrate/ Operate (SW307)

Adj. (R306)

Set screw potentiometer used to adjust the master controller for the calibration value of the load cell when (SW307) is in the calibrate mode. (See load cell calibration plug for calibration value).

Operate

Select the operate mode of load cell once calibration is complete.

3.1.12. Power (SW301)

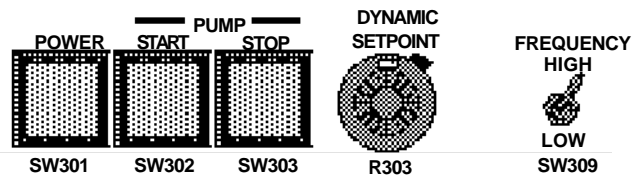

Front Panel (Right) - Bottom Section

Push switch for supplying power to master controller.

3.1.13. Pump**Start (SW302)**

Push switch with internal red indicator light to energize power supply.

Stop (SW303)

Push switch to de-energize hydraulic power supply.

3.1.14. Dynamic Set Point (R303)

Indicates desired peak dynamic level. Calibrated in engineering units. **See 3.1.4.**

3.1.15. Frequency Range - HIGH/ LOW (SW309)

HIGH - Compressor control of dynamic signal at 5 Hz and above.
LOW - Single loop control of force or displacement.

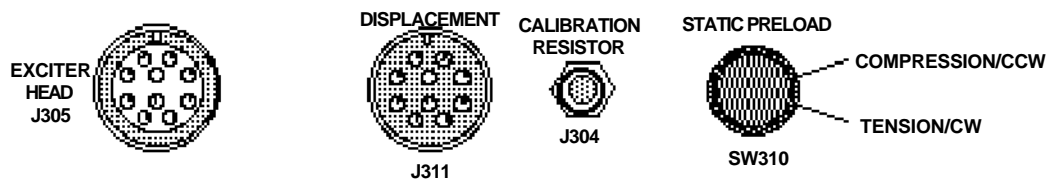
3.2. Rear Panel

Rear Panel - Top Section

3.2.1. Exciter Head (J305)

Input connection for servovalve and load cell cable from exciter head.

3.2.2. Displacement (J311)

Input connection for displacement transducer cable from exciter head.

3.2.3. Calibration Resistor (J304)

Jack input for calibration plug provided with Load Cell Transducer.

3.2.4. Static Preload (SW310)

Dual-position switch establishes sign convention of static preload. When exciter head is operated by “pushing” on the test article, this switch should be in the *COMPRESSION* position. If exciter head is operated by “pulling” on the test structure, this switch should be in the *TENSION* position.

3.2.5. Interlock (J306)

Input connect for interlock function. If external control of this function is not desired, an Xcite supplied mating connector with pins C and D shorted must be used. If user supplied external control is desired, then appropriate contact closure between pins C and D must be supplied. Pins A and B are supplied for interlock of additional external equipment, as required.

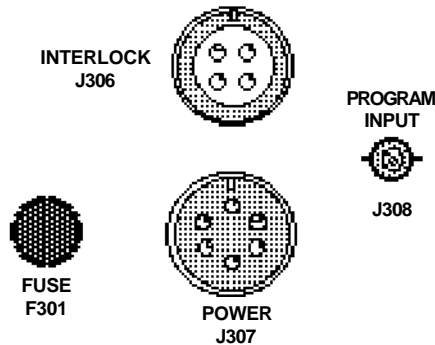

Rear Panel (Left) - Bottom Section

3.2.6. Power (J307)

Input connection for cable from hydraulic power supply. When a non-Xcite hydraulic power supply is used, this is the input connection for the direct 110V AC power cord.

3.2.7. Fuse (F301)

Use 3 amp fuse for 115 VAC. Use 1.5 amp fuse for 230 VAC.

3.2.8. Program Input (J308)

Input connection for signal from reference oscillator.



A 1 volt RMS signal must be provided to ensure system control calibration.

3.2.9. Controlled Variable - Static

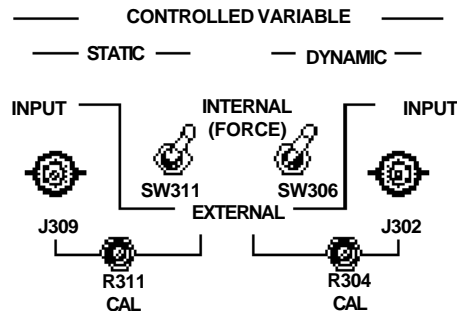

Rear Panel (Middle) - Bottom Section

Input (J309)

Input BNC connection for externally supplied user-specified static feedback variable. Input signal level should be 5 volts minimum full scale. Also used for Displacement Transducer feedback from the Exciter Head.

Internal/ External (SW311)

Toggle switch to select as the static controlled variable either the internally available load cell transducer signal or an externally supplied user-specified static feedback signal.

Cal. (R311)

Set screw potentiometer used to scale externally supplied static feedback variable to 5 volts full scale. Factory set for scaling 10 volts to 5 volts.

3.2.10. Controlled Variable - Dynamic

Input (J302)

BNC connection for externally supplied user-specified dynamic feedback variable. Input signal level should be 5 volts peak (minimum) full scale.

Internal/ External (SW306)

Toggle switch to select as the dynamic controlled variable either the internally available load cell transducer signal or an externally supplied user-specified dynamic feedback signal such as acceleration.

Cal. (R304)

Set screw potentiometer used to scale down externally supplied dynamic feedback variable to 5 volts peak full scale.

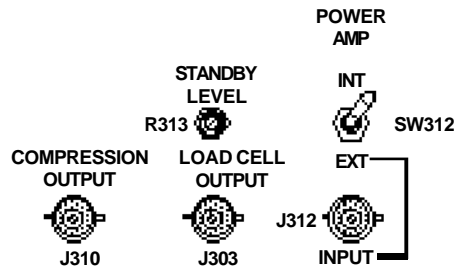

Rear Panel (Left) - Bottom Section

- 3.2.11. Compression Output (J310)**
BNC connection providing an output signal which is proportional to dynamic forward control signal (servovalve drive signal) after multiplication by reference oscillator signal.
- 3.2.12. Standby Level (R313)**
Set screw potentiometer determining static level when Master Controller is in standby or interlock mode.
- 3.2.13. Load Cell Output (J303)**
BNC connector providing load cell output signal for monitoring of the force signal (+/- 10V max). Duplicated on front of controller.
- 3.2.14. Power Amp - INT/ EXT (SW312)**
Toggle switch to select input signal to power amplifier. *INTERNAL* position is used for normal operation and provides dynamic control signal proportional to level requested on the front of the Master Controller at the reference oscillator frequency. *EXTERNAL* position is used for external dynamic control applications such as random or shaped random signals from an FFT Analyzer or random noise generator. In *EXTERNAL* position, the *DYNAMIC SET POINT* (R303) potentiometer on the front panel attenuates the external dynamic control signal and the *DYNAMIC SIGNAL LEVEL METER* (M-102) indicates 1.41 times the true RMS voltage of the dynamic variable feedback level.
- 3.2.15. Power Amp - INPUT (J312)**
BNC connector used to supply external control signal source with *POWER AMP* toggle switch on *EXTERNAL*. Use only J308 *PROGRAM INPUT* with toggle switch on *INTERNAL*.

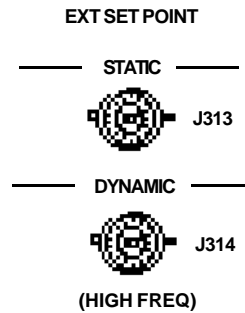

Rear Panel (Right) - Top Section

3.2.16. EXT Set Point - Static (J313)

Allows computer control of the Static Set Point by inputting a voltage from a DAC (Digital to Analog Converter). Typically this function is used when it is desired to have an automatic test sequence from a computer controlled FFT Analyzer.



CAUTION: This input is ALWAYS live and will activate the static control loop whenever a DAC voltage is present.

The EXT Static Set Point has the following characteristics:

- It is **ALWAYS** operable in the Standby, Static and Static + Dynamic modes.
- The input voltage from the DAC should be 0 to +5VDC, +/-5% to achieve full scale control of the Static Controlled Variable. (For the ES-315 Torsional Head, 2.5 volts)

Note: Always use a positive DC DAC voltage for this function.

- The input voltage from the DAC will add to the Static Set Point. (ie - If the Static Set Point Dial is set to 5.0 (1/2 of full stroke in displacement mode) then the EXT DAC voltage input will add to the Set Point on the Set Point Dial.

3.2.17. EXT Set Point - Dynamic (J314)

Allows computer control of the Dynamic Set Point by inputting a voltage (NOT frequency) from a DAC (Digital to Analog Convertor). Typically this function is used when it is desired to have an automatic test sequence from a computer controlled FFT Analyzer.



CAUTION: *This input is live when the Mode Control Switch is in the Static + Dynamic Mode. Dynamic Force output will occur whenever a DAC voltage is present at this input.*

The EXT Dynamic Set Point has the following characteristics:

- It operates in the Static + Dynamic Mode.
- It only operates in the High Frequency Range

Note: Never use in the Low Frequency Range Mode

- The input voltage from the DAC should be 0 to -5VDC, +/-10% to achieve full scale control of the Dynamic Controlled Variable.

Note: Always use a negative DC DAC voltage for this function.

- The input voltage from the DAC will add to the Dynamic Set Point. (ie - If the Dynamic Set Point Dial is set to 5.0, then the EXT DAC voltage input will add to the Set Point value. In this example a DAC voltage of -2.5V will make the Set Point 100%).

4. Operation

4.1. Concept of Operation

The Xcite Master Controller is designed so that the variables to be controlled can be readily selected by the positions of the Controlled Variable switches located on the rear panel of the controller.

When the Controlled Variable switches are in the Internal position, the controlled variable will be force. The force feedback signal is internally routed to the static and dynamic control loops. The composite force signal is separated by a low-pass and high-pass filter, with the DC and AC levels of the composite signal being displayed by the Static and Dynamic meters, respectively.

If a variable(s) other than force is to be controlled, the Controlled Variable switches can be placed in the External position and feedback from the variable to be controlled can be applied to the External Static and/ or External Dynamic inputs. This allows alternate variables such as displacement to be statically and dynamically controlled, or two variables such as static displacement and dynamic force to be controlled.

4.2. System Interconnection

Mount the exciter head to be operated securely in its test configuration and connect the hydraulic pump hoses to the exciter.

- 4.2.1. Exciter head cable (J305 to servovalve and load cell)
- 4.2.2. Displacement kit cable (J311 to exciter displacement kit)
- 4.2.3. Power cord or pump cable (J307 to J501 or 110 VAC)
- 4.2.4. Reference oscillator to Program input J308 (1 V RMS +/- 50 MV)
- 4.2.5. Connect an oscilloscope and/ or D.V.M. to Load Cell outputs J301 or J303.

4.3. Operation - Force Control

To operate the exciter under force control, place the following switches and controls in the positions given.

4.3.1. Set Controls

MODE CONTROL	STANDBY/RESET
DITHER	OFF
LOOP GAIN	FIXED (If test specimen static stiffness is less than 10,000 lbs/inch, place in variable & set variable gain control at 5.00)
FREQUENCY RANGE	HIGH
STATIC SET POINT	0
DYNAMIC SET POINT	0
STATIC CONTROLLED VARIABLE	INTERNAL
DYNAMIC CONTROLLED VARIABLE	INTERNAL
TENSION/ COMPRESSION	COMPRESSION

4.3.2. Depress the Power switch

The controller will energize and a momentary deflection of the meter pointers may occur.

4.3.3. Adjust Load Cell

- Adjust the load cell zero adjust for 0 Volts on a digital volt meter. Refer to the Calibration plug located on the rear of the controller for the load cell calibrate value and the output sensitivity of the controller.
- Place the load cell calibrate switch in the calibrate position. If necessary, adjust the load cell calibrate screw until the voltage measured by the digital volt meter equals the calibration voltage. The calibration voltage equals the calibration value divided by the output sensitivity.

Example:

Cal. Value = 742 lbs

Output Sens. = 250 lbs/v

therefore: $742/250 = 2.968v$ at J301/ J303

- Return the load cell calibrate switch to the operate position.

4.3.4. Depress Pump Start Button

The Hydraulic Power Supply should energize.

- Set the Mode Control switch to the Static position.
- Slowly turn the Static Set Point clockwise until the required static force is obtained, as indicated on the Static Meter. If operating into a "weak" structure, static force instability may occur. If this should happen, adjust the Variable loop gain counterclockwise until static stability is achieved.
- Set the reference oscillator to the desired excitation frequency.
- Set the Mode Control switch to Static + Dynamic position.
- Turn the Dynamic Set Point clockwise until the desired dynamic force is obtained.

Note: Refer to the Exciter Head specifications for maximum peak force versus frequency.

- If swept sine test are to be run, the sweep rate of the oscillator will have to be adjusted so that the dynamic level does not decrease as the frequency is swept upward. If this occurs, lower the sweep rate until the dynamic level is maintained as the oscillator frequency is swept.

4.4. Operation - Displacement Control

If the exciter head is to be operated under displacement control, place the controller switches in the following positions.

4.4.1. Set Controls

MODE CONTROL	STANDBY/RESET
DITHER	OFF
LOOP GAIN	VARIABLE (Variable loop gain control at 5.00)
FREQUENCY RANGE	LOW
STATIC LEVEL	0
DYNAMIC LEVEL	0
STATIC CONTROLLED VARIABLE	EXTERNAL
DYNAMIC CONTROLLED VARIABLE	INTERNAL
TENSION/ COMPRESSION	COMPRESSION

- Energize the controller and the hydraulic power supply.
- Switch the Mode Control to the Static position.
- Turn the Static Set Point potentiometer until the desired static position is reached. The static position can be read on the Static Meter in percent of full stroke. For instance, if the exciter head being used has a 1 inch stroke and the Static meter reads 40%, then the exciter piston is extended 40% of one inch or .4 inch.

The exciter piston position can be dynamically varied by turning the Mode Control switch to the Static + Dynamic position and adjusting the Dynamic Level control for the desired stroke. The Dynamic meter will not indicate the peak displacement in this mode of operation. It will be necessary to monitor the displacement signal at the External Static Variable input jack J309. The input signal at this point will be 0 - 10 VDC. If the exciter has a 1 inch stroke, then full stroke will be equal to 10 VDC. On torsional exciters, 10 VDC represents 100 degrees of rotation.

If compressor control is desired, the Frequency Range should be set to the High position and the displacement input also connected to the Dynamic External Static input J302. At frequencies below approximately 5 Hz full stroke of the exciter may not be obtained in the High Frequency mode. However, the amplitude of the 1 V RMS signal from the reference oscillator may be increased to obtain a slightly larger dynamic stroke.

4.5. Operation - External Variable

Operation using the External Static and Dynamic controlled variable inputs is very similar to the operation using the internal controlled variable. One requirement, however, is that the external variables be scaled to the full scale value of the Static and Dynamic meters. This is accomplished by adjusting the External Cal. potentiometers. A 5 VDC signal is required for full scale deflection of the Static meter and a 5 V peak signal is required for full scale deflection of the Dynamic meter. The Static External Cal. potentiometer is factory adjusted for 10 VDC full scale static signal. The Dynamic Cal. potentiometer is adjusted for a 5 V peak dynamic signal. If signals larger than these are to be used, the Cal. potentiometer should be readjusted so that those signals will cause full scale deflection of the meters.

4.6. Computer Control - External Set Points (Static and Dynamic)

As explained in Section 3.2.16. and Section 3.2.17., it is possible to have a computer controlled FFT Analyzer control the Static and Dynamic Set Points of the Master Controller. Separate DAC output voltages are required for the Static Set Point and Dynamic Set Points. The Static DAC output must be a positive voltage and the Dynamic DAC output must be a negative voltage.

When using an external computer to input the Static and Dynamic Set Points, attention must be paid to the consequences of inputting a DAC voltage when the Hydraulic Power Supply is turned on. The Exciter Head will attempt to operate when these signals are present even with the Mode Control Switch in Standby.

STRUCTURE DAMAGE OR PERSONAL INJURY CAN OCCUR IF THE TEST SEQUENCE IS NOT THOROUGHLY PLANNED.

5. Theory of Operation

The Xcite Master Controller consists of seven major circuits. They are:

- Static control circuitry
- Dynamic control circuitry
- Power amplifier
- Load cell amplifier
- Displacement transducer buffer/ amplifier
- Interlock circuitry
- Pump/ start/ stop

Each section is described in detail as follows.

5.1. Circuit Descriptions

Refer to the Master Controller block diagram and to the appropriate printed circuit board schematics for the following circuit descriptions.

5.1.1. VR101 (Voltage Regulator)

Provides the excitation voltage for the load cell. The regulated voltage is determined by the values of R169 and R170.

$$V_{out} = \frac{1.25V(1 + R170)}{R169}$$

To calibrate the load cell, place a precision shunt resistance (Cal. Plug provided with each load cell) into J304 and place the load cell calibrate/ operate switch SW307 in the calibrate position. This causes an imbalance of the load cell bridge and results in an output of the load cell amplifier A109. The excitation voltage to the load cell is then varied by adjusting R306 until the output of A109 corresponds to the calibration value of the load cell, as given on the calibration plug.

5.1.2. SW310 (Preload Switch)

Allows the outputs of the load cell to be reversed before being applied to A109. This will cause the exciter head to operate in a tension mode, instead of a compression mode.

5.1.3. A109 (Amplifier)

A109 is a precision differential instrumentation amplifier used to amplify the differential voltages from the load cell bridge. R166 and A108 allow the output of A109 to be scaled to a convenient engineering unit for monitoring purposes. The output of A108 is available at BNC jacks on the front and rear of the Master Controller.

The output of A109 is also applied to SW311 and SW306. When these switches are in the *INTERNAL* position, the force signal is applied to the static and dynamic loops as the feedback signal and controlled variable.

5.1.4. **A104 and A105 (Static Control Loop)**

The static control loop consists of A105 and A104. A105 is a dual op-amp. A105B is a low-pass filter which allows the static portion of the feedback signal to be indicated by the static meter. A105A is an inverter/ buffer stage. R137 allows calibration of the dynamic level control when operating in the *LOW FREQUENCY* force control. R135 allows calibration in the *LOW FREQUENCY* displacement control.

The feedback signal from A105A is summed with the static level signal at the summing junction of A104. A104 is a low-pass filter which provides high DC gain which rolls off at 6DB/ octave at a breakpoint determined by R174 and C108. R176, R102 and R113 determine the DC gain of A104. The output of A104 is applied through SW311 and / or K201 and to the appropriate feedback path as determined by the controlled variable.

The output of A104 is also applied to R133 and enables the static loop gain to be adjusted for optimum operation of the exciter head under force control. Further operator adjustment of the static loop gain is provided by R307 when the *GAIN* switch SW305 is in the *VARIABLE* position.

5.1.5. **A401 and A402 (Dynamic Loop)**

The dynamic loop has two main circuits. One circuit, consisting of A401 and A402, demodulates the incoming reference frequency and converts it to a DC reference signal which is applied to the Dynamic Level Control, R303.

The dynamic demodulator circuit consist of a low-pass filter A103, and a true RMS-to-DC converter, U102. The DC portion of the force signal is blocked by C109. The output of U102 is a DC signal. This DC is summed with the dynamic set point signal from the wiper of R303. The resultant error signal is integrated by A012 and C104. This DC error signal is applied to one input of the four-quadrant multiplier, U101. The reference frequency supplied by the reference oscillator is supplied to the other input of U101. The output of U101 is a signal with

a frequency identical to the reference frequency and with an amplitude equal to the product of the two input signals. A101A converts the current output of U101 to a voltage. A101B provides output offset capabilities. C101 and C102 allow the dynamic signal to have two breakpoints at higher frequencies, as required to prevent the servovalve drive signal from clipping.

The output of U101 and A104 are applied to summing amplifier A201. The dither signal is also summed at this point if it is selected by the dither switch. The output of A202 is a composite error signal which is then applied to the power amplifier.

The power amplifier is a voltage-to-current converter circuit. The output current will remain constant for a given input voltage, even though the load impedance (servovalve coils) changes.

5.1.6. A107 (Inverter Buffer)

This circuit allows the displacement transducer to be offset and scaled to convenient engineering units. The scaled displacement signal is fed out through J311/ G into a BNC cable which is then connected to J309. By placing the Static controlled variable switch in the External position, displacement will become the static controlled variable.

5.1.7. A106 and U103 (Peak Detector Circuit)

A106 and U103 form a peak detector circuit which can be adjusted if an absolute value of displacement is exceeded. It is primarily used with inertial mass exciter heads, and only appears in Master Controllers with the MOD2 option.

The interlock circuitry provides a means of insuring that the systems always power up to a preset level, determined by Standby level pot. If power is applied to the Master Controller with the Mode Control switch in either the Static or Static + Dynamic position, the system will interlock. The Mode Control switch must then be placed in the Standby/ Reset position. The Hydraulic Power Supply must also be energized before proceeding to the desired mode of operation.

6. Specifications

Modes:

- | | |
|------------------------------------|---|
| • Standby/ Reset | Continuously variable standby level |
| • Static | Continuously variable static level |
| • Static + Dynamic | Continuously variable static level and dynamic level |
| • External Static Input | 10 K ohms input impedance
Positive polarity 0 - 10V |
| • External Dynamic Input | 10 K ohms input impedance
10 V peak AC |
| • Dither | 400 Hz +/- 10% |
| • Control Accuracy | 40 dB of full scale controlled variable |
| • Program Input Reference Signal | 1.0 VAC RMS +/- 50 MV - sinusoidal
5.0 V peak maximum - random |
| • Power Amp Input Reference Signal | 0 to 5 Volt Peak |
| • EXT Static Set Point | 0 to +5VDC for full scale operation |
| • EXT Dynamic Set Point | 0 to -5VDC for full scale operation |

7. Drawings

Controller Schematic	D-015393
Block Diagram Master Controller (2 sheets)	D-015391
Schematic PCB 110-01 Sheet 3 - Load Cell Amp & Peak-Detector	C-015358
Schematic PCB 110-01 Sheet 1 - Static Loop	C-015358
Schematic PCB 110-01 Sheet 2 - Dynamic Loop	C-015358
PCB 110-01 (Component Location)	D-015384
Schematic PCB 110-02	C-014893
Assy PCB 110-02 (Component Location)	C-014881
Schematic PCB 110-04	C-010660
Assy PCB 110-04 (Component Location)	C-014882
PCB110-05 Romass Schematic	C-015528-3

8. Parts List

Xcite reserves the right to substitute parts without notice.

Component Part Number	Description
<u>Chassis</u>	
R301, 303, 307	1K, 10 Turn 5000 Series Pot
R302	50K, Trim Pot 3059J-1-503-M
R304, 311, 313	10K, Trim Pot 3059J-1-103-M
R305	Load Cell Dependent Phone Jack
R306	500 Ohm, Trim Pot 3059J-1-501-M
R308, 309, 310	47K, 1/2W, 5%
R312	110K, 1/4W, 5%
R314	100 Ohms, 1/4W, 5%
C301	50 MFD, 50V 7121L (39D)
T301, 302	Transformer, F-90X
T303	Supply, HAA-15-8
F301	Fuse, AGC 3, 3 amp
SW301	5A DPDT, 520-101G-51-A1H
SW302, 303	5A SPUT, 518-1016-51-A1H
SW304	Rotary 4P3T, 44A60-04-1-3N
SW305, 309, 311	4PDT Locking Toggle, MTL-406N
SW306, 312	DPDT Locking Toggle, MTL-206N
SW307, 308	SPDT Locking Toggle, MTL-106D
SW310	Rotary 5PDT, 71B30, 01-5-02N
M101, 102	100 Microamp, 4.5", 7045-3602-0000 API
J301, 302, 303	BNC Connector, UG-1094A/U
J304	Phone Jack, 12-B
J305	MS3102A-18-1S
J306	MS3102A-18-4S
J307	MS3102A-18-12P
J311	MS3102A-18-1P
KN301	Knob, DS70-2BD-2 (Rear)
KN302	Knob, DS70-3-2 (Front)

Component Part Number	Description
KN303, 304, 305	Dial, Turns Counting, 2606
L301	515-0012, Lamp, 6.5. Lamp Holder
L302	RA877 Crimp Lug
<u>PCB 110-01</u>	
R101, 102, 112, 176	10K, 1/4W, 5%
R103	47K, 1/4W, 5%
R104, 131, 135, 137, 138, 142, 151, 172	50K, Trim Pot, 784 Series
R105	30K, 1/4W, 5%
R106, 121, 122, 123, 126, 140, 141, 144, 145, 146, 147, 173, 177	100K, 1/4W, 5%
R107	1K, Trim Pot, 784 Series
R108	330 Ohm, 1/4W, 5%
R109	50K, Trim Pot
R110, 115, 116	Not used
R111, 134	1K, 1/4W, 5%
R113	470K, 1/4W, 5%
R114, 132	51K, 1/4W, 5%
R117	16K, 1/4W, 5%
R118	62K, 1/4W, 5%
R119, 120, 128, 129	20K, Trim Pot, 784 Series
R124, 133, 166	10K, Trim Pot, 784 Series
R125	24K, 1/4W, 5%
R127, 180	27K, 1/4W, 5%
R130	2.2M, 1/4W, 5%
R136, 143, 171, 175, 178	1M, 1/4W, 5%
R139	39K, 1/4W, 5%
*R148	240K, 1/4W, 5%
*R149	100K, 1/4W, 1%
*R150	510 Ohm, 1/4W, 5%
R152, 170	200 Ohm, 1/4W, 5%
R153	5K, Trim Pot, 784 Series
*R154, 182	10K, 1/4W, 5%
*R155, *158, *159, 160, 179	200K, 1/4W, 5%
R156, 157	20K, 1/4W, 5%
R161	1M, 1/4W, 1%
R162, 163	499 Ohms, 1/4W, 1%
R164, 165	100 Ohms, 1/4W, 5%
R167	100K, Trim Pot, 784 Series

Component Part Number	Description
R168	953K, 1/4W, 1%
R169	2.2K, 1/4W, 5%
R174	1M, 1/4W, 5%, Mod 4, 100K, 1/4W, 5%, Mod 2
*R181	30K, 1/4W, 5%
*R182	10K, 1/4W, 5%
R183	22K, 1/4W, 5%
R184	100K, 1/4W, 5%
R185	147K, 1/4W, 5%
C101	.68 MF Mod 4, .068 MF Mod 2
C102	.001 MF, 160-.015-20-400-C
C103, 110	Not Used
C104, 111, 112, 113	10 MF, 20V Dipped Tant.
C105	15 MF, 20V Dipped Tant.
C106	4.7 MF, 20V Dipped Tant.
C107, 114	1 MF, 20V Dipped Tant.
C108	4.7 MF, 100V 160-4.7-20-100-H (Mod 4 option only) (Not used for Mod 2)
C109	.68 MF, 100V 160-.68-20-100-D
C115	.0022 MF, 160-.0022-400-C
CR101, 102, 107	Not Used
CR103, *105, *106, *108	IN914
CR104	IN4737A
CR109	
U101	MC1494L
U102	AD536AJD
*U103	MC14013B
VR101	LM317LZ
A101, 105, *106	MC1458CP1
A102, 108	MC1741CP
A103, 104, 107	LF13741N
A109	LM308AN
K101	SPST, 360-12-1A
*Q101	MPSA13

Component Part Number**Description****PCB 110-02**

R201, 202	47 Ohm, 1/2W, 5%
R203	Not Used
R204	20K, 1/4W, 5%
R205	470K, 1/4W, 5%
R206, 209	1K, 1/4W, 5%
R207, 219, 222, 225	10K, 1/4W, 5%
R208, 212, 216, 221, 224	100K, 1/4W, 5%
R210	220K, 1/4W, 5%
R211	10K, 2W, 5%
R213, 214	820 Ohm, 1/4W, 5%
R215, 223	Not Used
R217, 218	10 Ohm, 1/2W, 5%
R220	3.6K, 1/4W, 5%
R226	1K, Trim Pot, 784 Series
R227	10K, 1/4W, 5%
R250	Valve Dependent, 1/4W, 5%
C201, 202	50 MF, 75V TVA-1343
C203, 205, 207	Not Used
C204	.047 MF, 160-.015-400-C
C206	.01 MF, 160-.01-630-C
C208	.033 MF, 160-.033-250-C
CR201 thru 211	IN5059
A201, 202	LF356N
K201, 202	Relay, 4PDT 1315-4C-12VDC
Q201	2N697
Q202	2N4036
Q203	2N3440
Q204	2N3441
Q205	2N5632
Q206	2N6229

Component Part Number**Description****PCB 110-04**

R401, 403, 405, 408, 416, 417, 418	Not Used
R402, 411	50K, Trim Pot, 784 Series
R404, 406, 426, 428	20K, 1/4W, 5%
R407	30K, 1/4W, 5%
R409, 413	1M, 1/4W, 5%
R410	100K, 1/4W, 5%
R412	10M, 1/4W, 5%
R414	140K, 1/4W, 5%
R415	47 Ohm, 1/4W, 5%
R419, 427	10K, 1/4w, 5%
R420, 421	39K, 1/4W, 5%
R422	470K, 1/4W, 5%
R423	4.7K, 1/4W, 5%
R424	4.3K, 1/4W, 5%
R425	8.2K, 1/4W, 5%
R429	15K, 1/4W, 5%
R430	6.2K, 1/4W, 5%
C401, 402	10 MF, 20V, Dipped Tant.
C403	68 MF, 20V, Dipped Tant.
C404	15 MF, 20V, Dipped Tant.
C405, 406	.01 MF, 160-.01-10-630-C
C407, 408	.1 MF, 160-.1-10-100-C
CR401, 402	N914
CR403	Not Used
CR404	IN5059
K401	Relay, 1310-4C-210AG
K402	Relay, 1315-4C-T2VDC
A401	MC1458CP
A402, 403, 404	LF356 or LM741

9. Calibration

The Xcite Master Controller is calibrated at the factory. Recalibration is required only if certain active components are replaced, or if a potentiometer is replaced.

Calibration need not be done in the order listed, nor are all adjustments required if one circuit is to be re-calibrated. Individual calibration may be performed as needed.

- Before beginning calibration, disconnect the head cable from J305.
- With power off, zero the static and dynamic meters, using the adjustment screw beneath each meter face.
- With power on but the pump off, check the following adjustments and readjust as described, if necessary. Place the following switches and controls in the positions given:

DITHER	OFF
STATIC SET POINT	0
DYNAMIC SET POINT	0
MODE CONTROL	STATIC
STATIC CONTROLLED VARIABLE	EXTERNAL
DYNAMIC CONTROLLED VARIABLE	EXTERNAL
TENSION/ COMPRESSION	COMPRESSION/ CCW

9.1. Equipment Needed

- 9.1.1. Stiff Test Structure (capable of w/standing the full rated force of the Exciter Head)
- 9.1.2. A 4 ½ digit Digital Multimeter
- 9.1.3. Oscilloscope
- 9.1.4. Signal Generator (audio frequency range)
- 9.1.5. FFT Spectrum Analyzer (if curves are to be run)
- 9.1.6. Trim pot adjustment tool or a small screwdriver

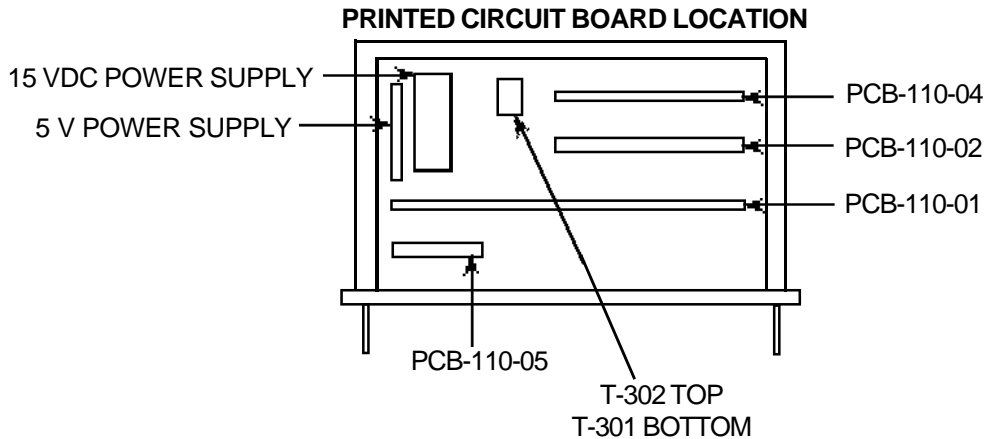

9.2. Master Controller

9.2.1. Meter Zero Adjustments

- Turn the Master Controller off.
- The Static and Dynamic meters should be resting precisely at zero.

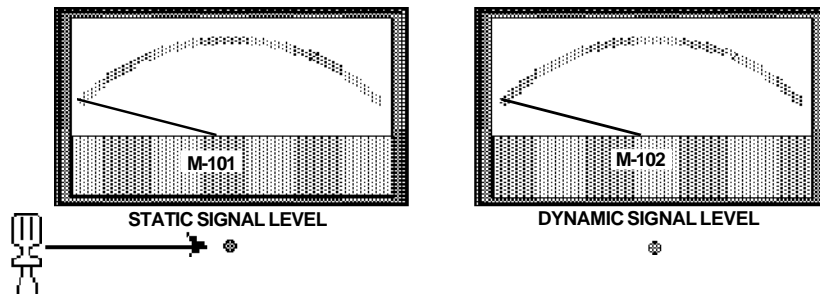

- If necessary, adjust the meters to zero using the small holes centered under each front panel meter.
- Turn the Master Controller on.

9.2.2. +/-15 Volt Supply Check

- Check for +15.00 Volts at 110-01-1 and -15.00 Volts at 110-01-3.
- If necessary adjust the supplies to within +/-10mV using the trim pots located on the power supply (mounted to the left rear of the chassis).

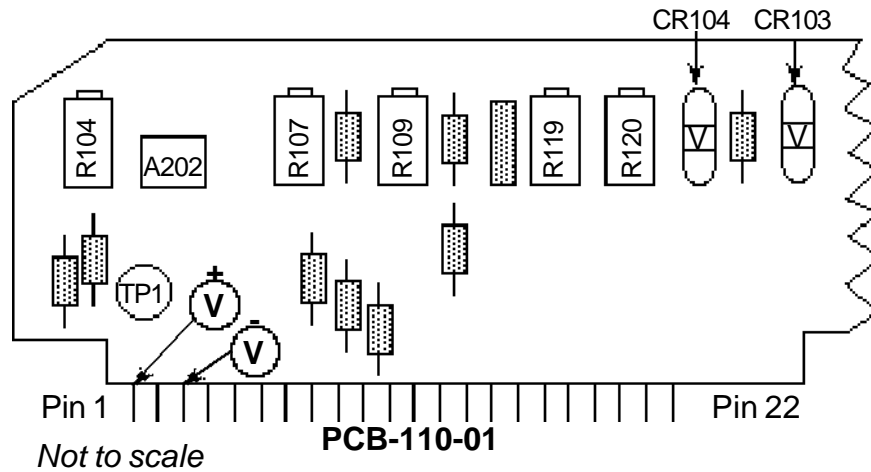

9.2.3. +/-60 Volt Supply Verification

Check for roughly +/-60 Volts at the large capacitors on the upper right corner of the 110-02 board. *No adjustment is possible.*

9.2.4. Load Cell Excitation Voltage Verification

Check for 12.0V +/- .3V at 110-01-44

9.2.5. Master Controller Board 110-04 Calibration Procedure

Initial Setup

Apply a shorted BNC cable or a 50Ω BNC terminator to the Program Input (J308).

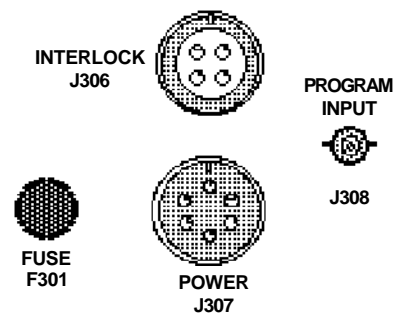

Program Input Offset Adjustment

Adjust R411 for 0mV at TP3.

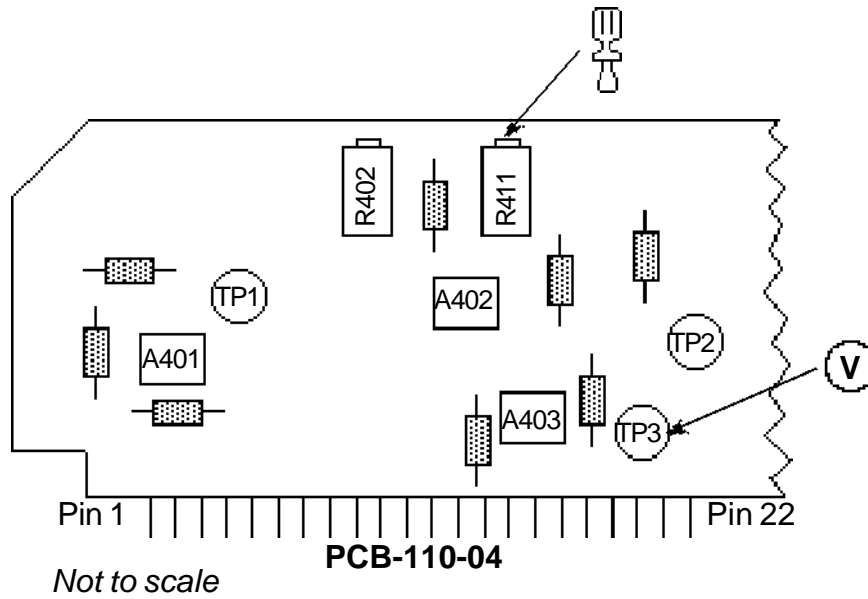

Dynamic Reference Offset Adjustment

Adjust R402 for 0mV at TP2.

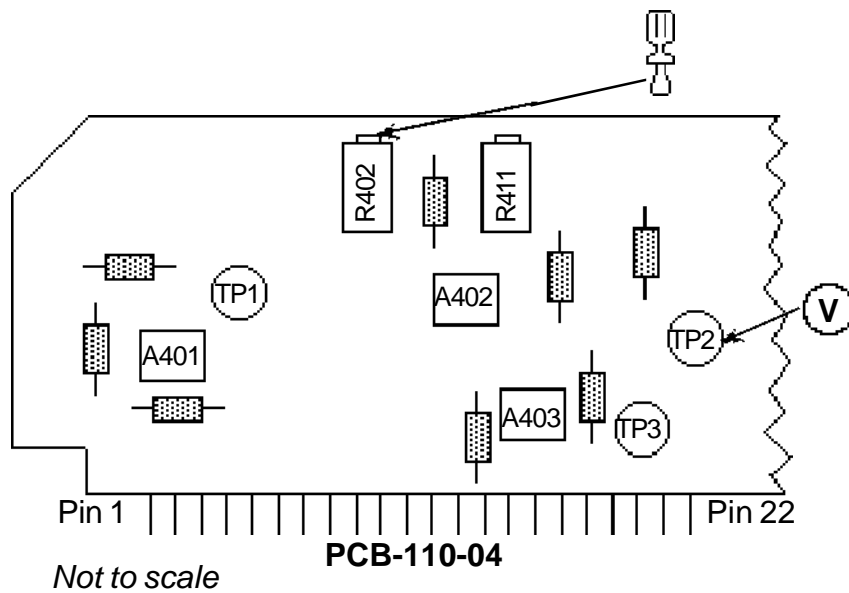

Dynamic Reference AC to DC Level Verification

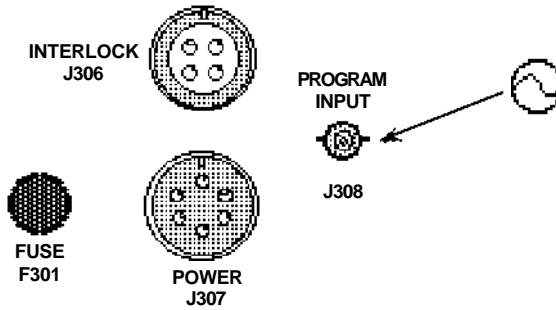

- Apply 1.000V rms to the Program Input (J308).
- Check for roughly -10.8V DC at TP2.
- Remove signal from the Program Input (J308).

Dither Oscillator Verification

Check for a 26V peak to peak, 360 Hz Triangle wave (+/-20 Hz) at TP4.

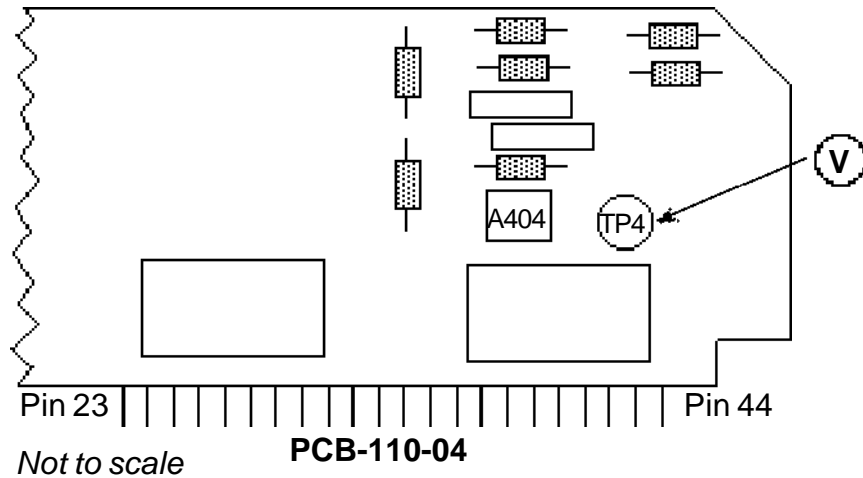

9.2.6. Master Controller Board 110-02 Calibration Procedure

Dither Level Calibration

- Set *DITHER* switch (SW308) to *ON*.
- Adjust R226 for 0.500V rms at 110-02-9.
- Set *DITHER* switch to *OFF*.

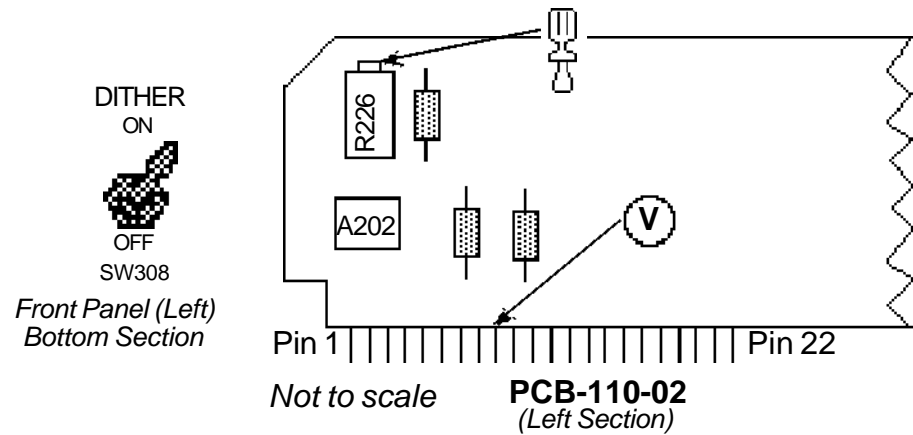

9.2.7. Master Controller Board 110-01 Calibration Procedure

Set front and rear panel switches and adjustments as follows:

Dither	(SW308)	Off
Load Cell Calibrate/ Operate	(SW307)	Operate
Frequency	(SW309)	Low
Power Amp Input	(SW312)	Internal
Static Preload	(SW310)	Compression
Static Controlled Variable	(SW311)	External
Dynamic Controlled Variable	(SW306)	External
Static Gain	(SW305)	Fixed
Standby Level	(R313)	Full CCW
Static Set Point Level	(R301)	0.0
Dynamic Set Point Level	(R303)	0.0
Static Gain Level	(R307)	5.0

External Static and Dynamic Variable Input Calibration

- Apply a 1.000V rms, 100 Hz sine wave to the External Static Variable Input (J309).
- Adjust External Static Cal (R311) for .500V rms at 110-01-28 (WHT/ RED wire).
- Apply a 1.000V rms, 100 Hz sine wave to the External Dynamic Variable Input (J302).
- Adjust External Dynamic Cal (R304) for .500V rms at 110-01-25 (WHT/ BLK wire).
- Remove signal

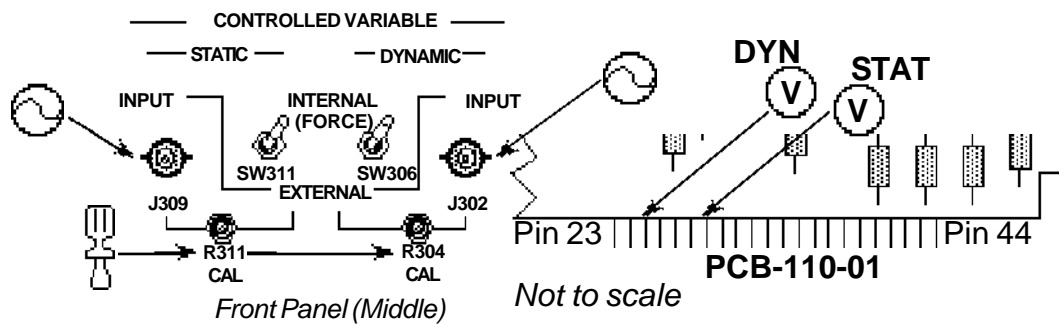

Load Cell Amplifier Common Mode Null Adjustment

- Apply a 1.000V rms, 100 Hz sine wave to 110-01-39 (BLK wire) and 110-01-41(SILVER wire).
- Adjust R167 for minimum 100 Hz signal at TP9.
- Remove signal from 110-01-39 and 110-01-41.

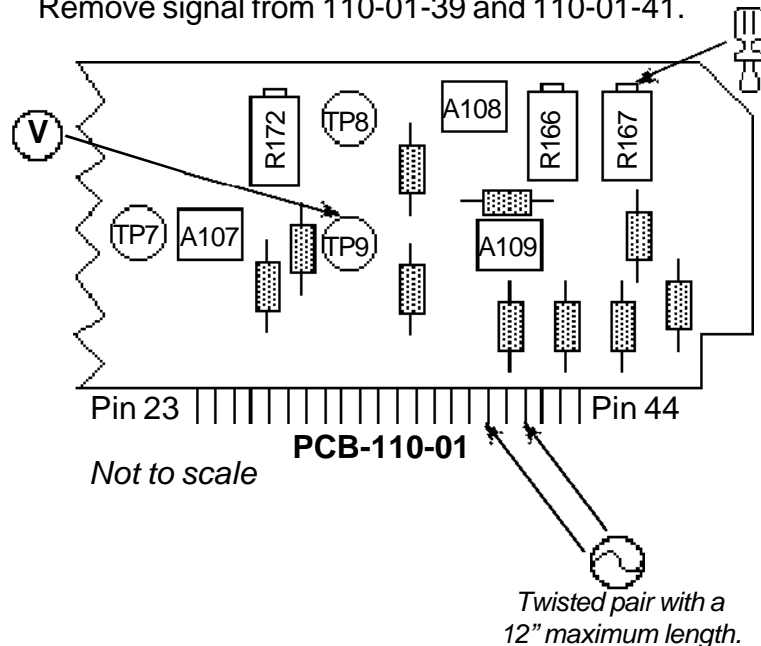

Meter Amplifier Zero Offset Adjustments

With no signals applied, make the following settings:

Static Set Point Level	(R301)	0.0
Dynamic Set Point Level	(R303)	0.0
Static Controlled Variable	(SW311)	External
Dynamic Controlled Variable	(SW306)	External

- Adjust (Static Offset) R142 for 0mV at TP6.
- Adjust (Dynamic Offset) R131 for 0mV at TP3.

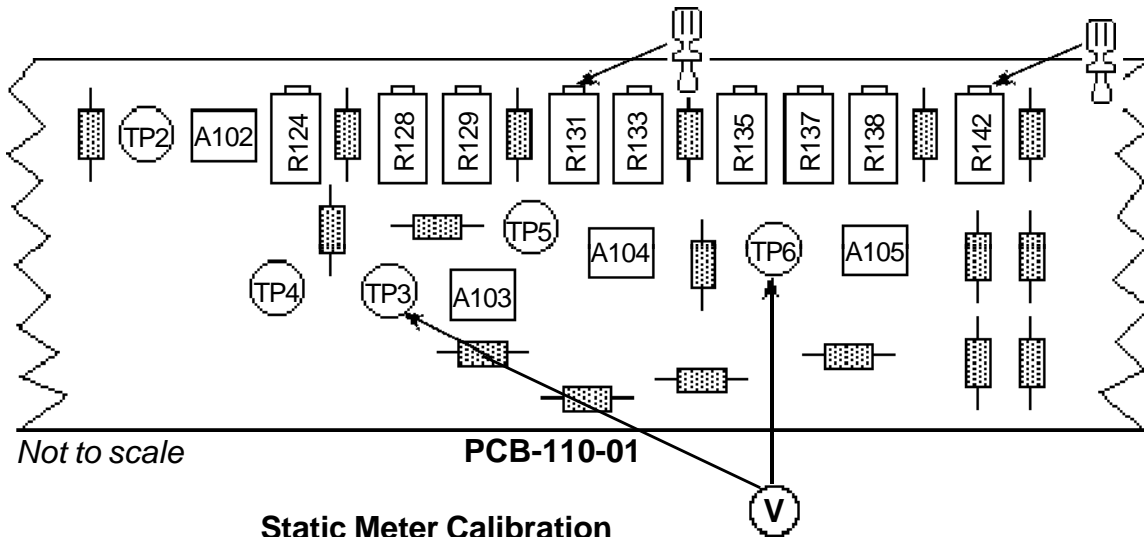

Static Meter Calibration

- Apply 5.000V DC at 110-01-28 (WHT/ RED wire).
- Adjust R138 to set Static Meter deflection at 100%.
- Remove signal from 110-01-28.

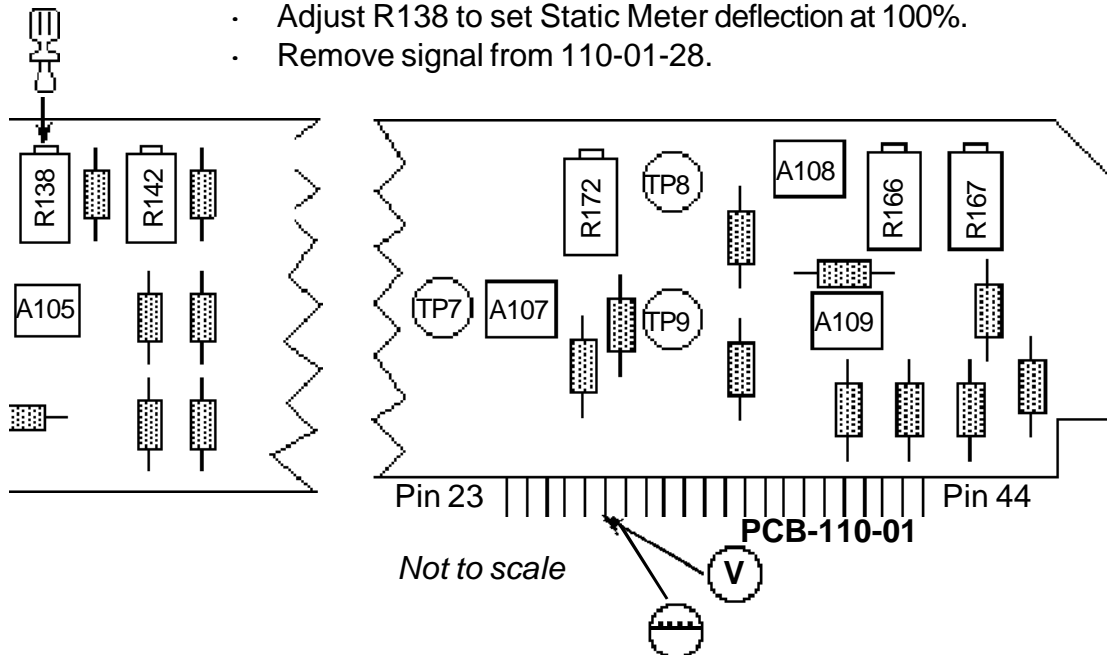

Dynamic Meter Calibration

Pre RMS Converter Check

- Set the Dynamic Control Variable (SW306) to External.
- Apply a 100 Hz sine wave to the Dynamic Variable Input (J302).
- Adjust Signal level for 1.000V rms at 110-01-25 (WHT/ BLK wire).
- Check for an inverted 1.0V rms +/-5% signal at TP3.

RMS Converter Check

Check for 1.00V DC at TP4.

Dynamic Meter Calibration Adjustment

- Adjust the signal level for 1.77V rms at 110-01-25 (WHT/BLK wire).
- Adjust R129 for 50% full scale deflection of Dynamic Meter.
- Remove signal from Dynamic Variable Input (J302).

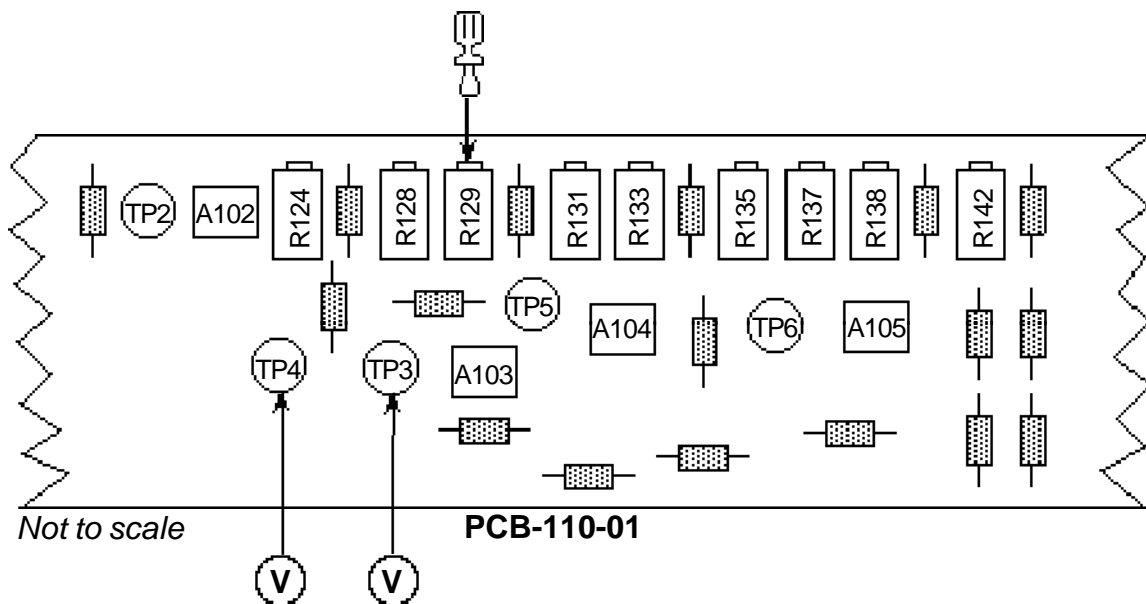
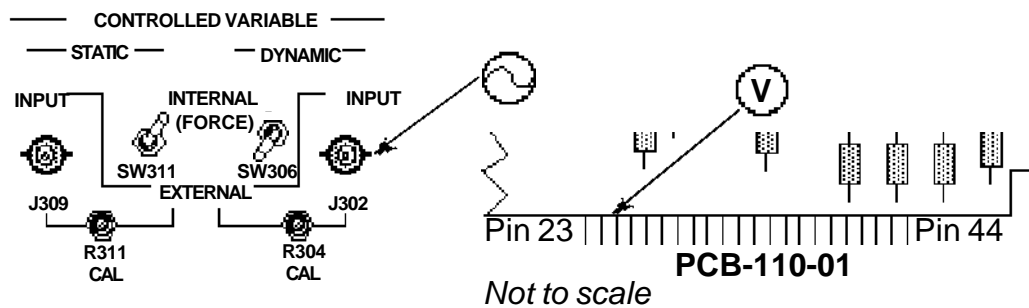

Dynamic Multiplier Calibration

Integrator Bias Calibration

Adjust R124 for -10mV DC at TP2.

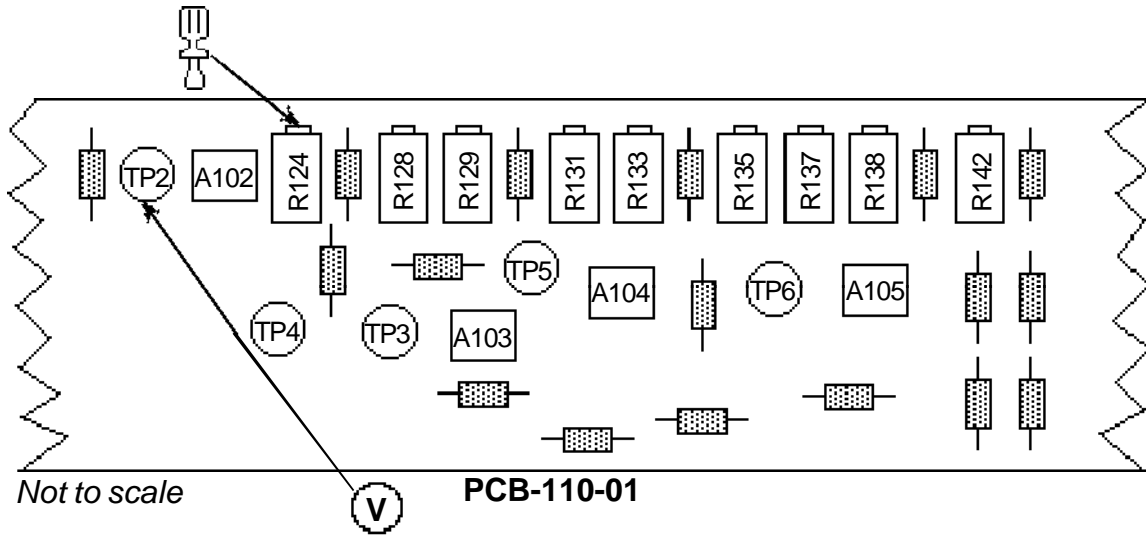

P-Clip Adjustment

Adjust R109 fully clockwise (to Maximum).

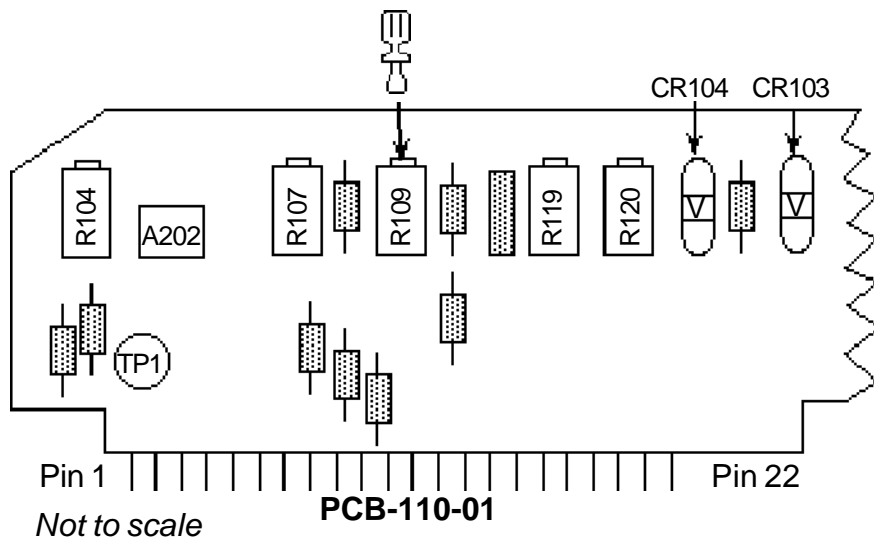

Initial Multiplier Offset Adjustment

Adjust R104 for 0mV DC +/-100mV at TP1.

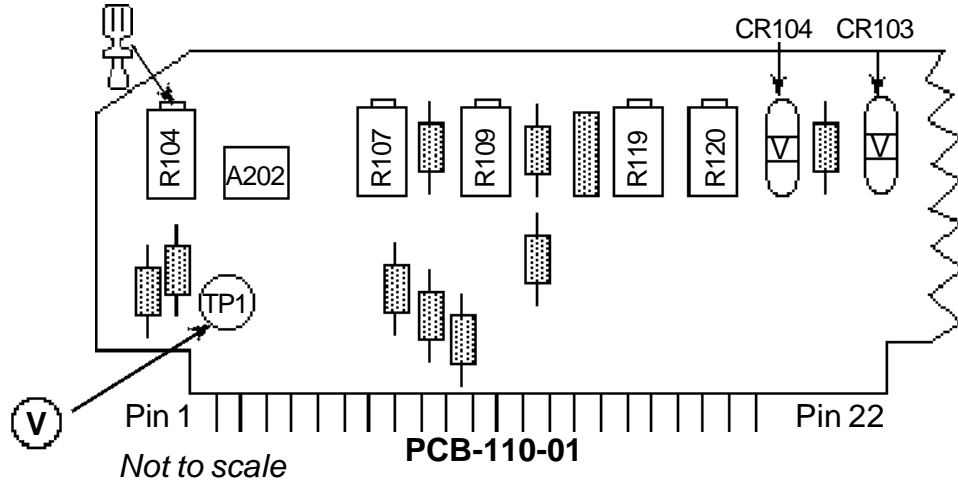

Multiplier X Input Null

- Apply a 1.0V rms, 120 Hz sine wave to the Cathode side of CR104.
- Adjust R119 for minimum 120 Hz signal at TP1.

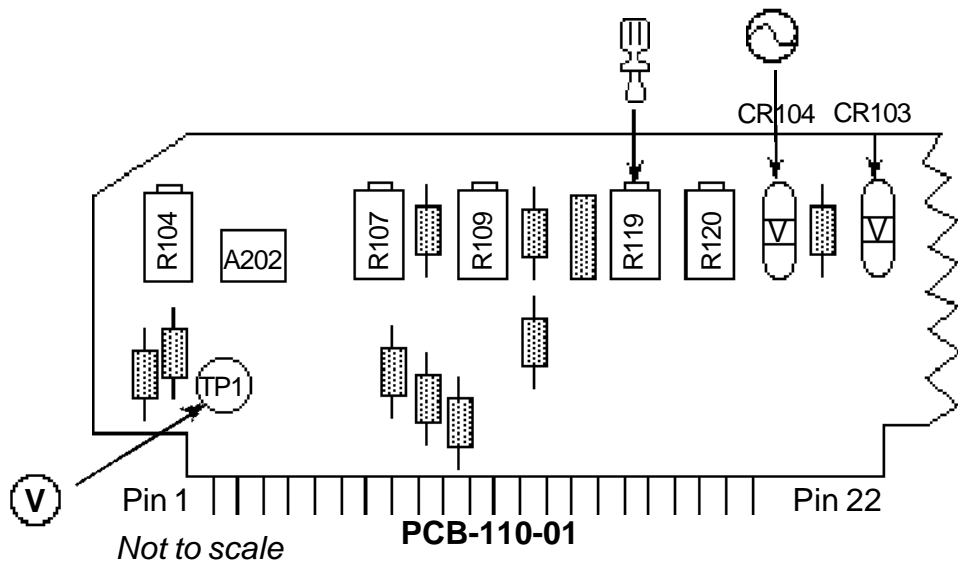

Multiplier Y Input Null

- Remove the signal from CR104.
- Apply a 1.0V rms, 120 Hz sine wave to the Program Input (J308).
- Adjust R120 for minimum 120 Hz signal at TP1.

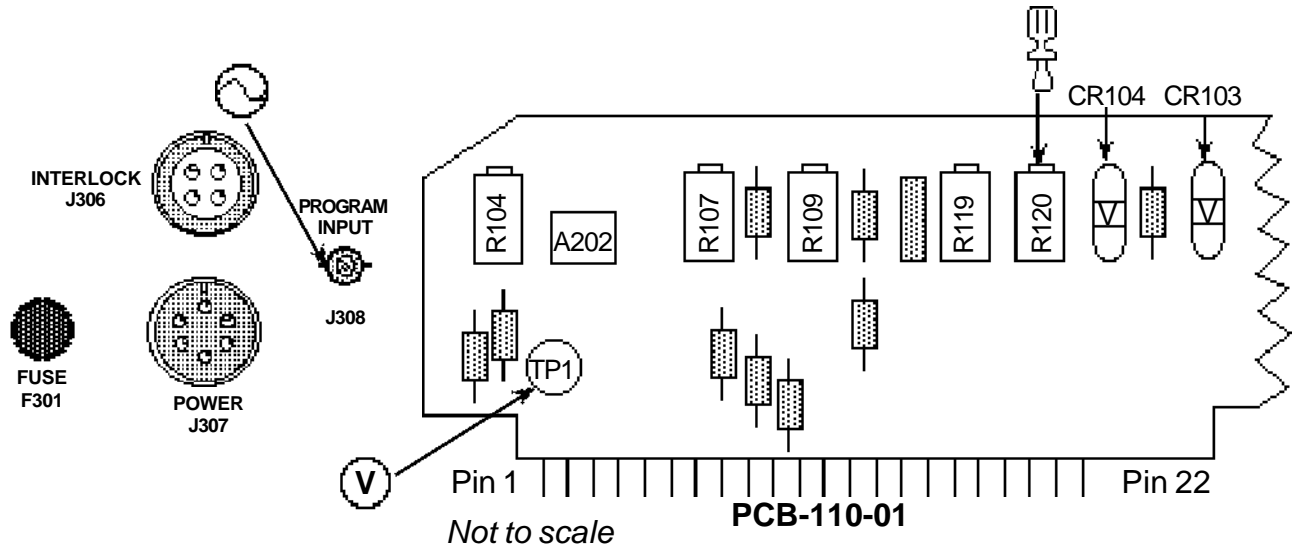

NOTE: Steps 2.4.7.4. and 2.4.7.5. may be slightly interactive. Repeat both adjustments until both inputs are nulled.

Final Multiplier Offset Adjustment

- Remove signal generator.
- Adjust R104 for 0mV +/-10mV at TP1.

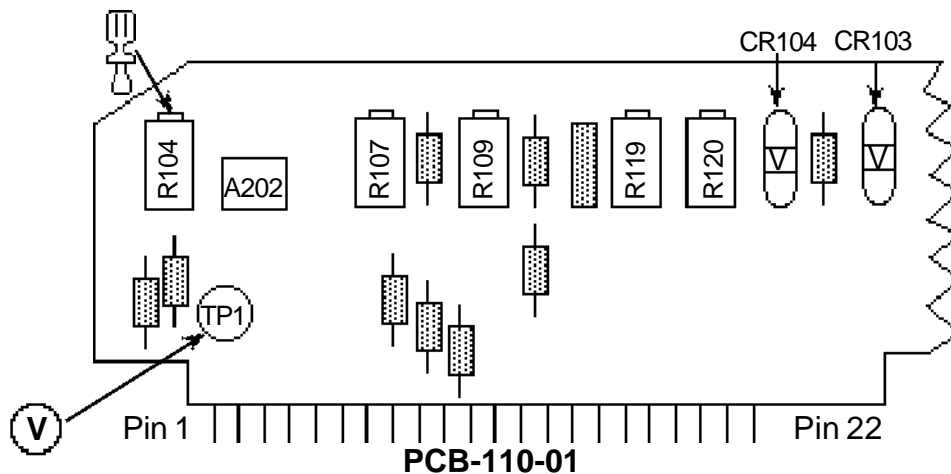

9.3. Exciter Head Calibration Procedure

Set front and rear panel switches and adjustments as follows:

Dither	(SW308)	Off
Load Cell Calibrate/ Operate	(SW307)	Operate
Frequency	(SW309)	Low
Power Amp Input	(SW312)	Internal
Static Preload	(SW310)	Compression
Static Controlled Variable	(SW311)	Internal
Dynamic Controlled Variable	(SW306)	Internal
Static Gain	(SW305)	Variable
Standby Level	(R313)	Full CCW
Static Set Point Level	(R301)	8.0
Dynamic Set Point Level	(R303)	5.0
Static Gain Level	(R307)	5.0

9.3.1. Load Cell Amplifier Calibration

Initial Setup

- Connect P305 end of the Controller Cable to J305 (Rear Panel).
- Connect the 4-pin cable to the load cell.
- Insert the Cal Plug into J304.

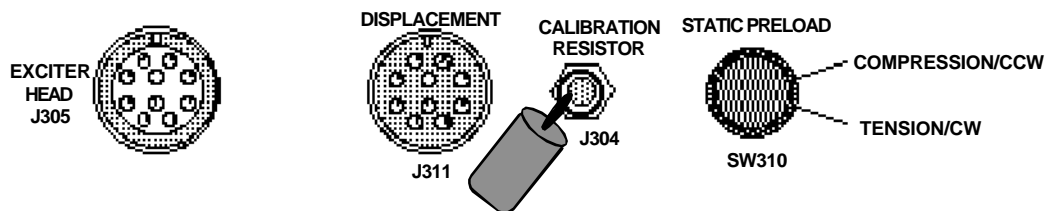

NOTE: The following two adjustments are very interactive; it will be necessary to repeat both adjustments until an acceptable balance is achieved.

Adjust Load Cell Zero Calibration

- Set the Load Cell Operate/ Calibrate Switch (SW307) to *OPERATE*.
- Adjust the Load Cell Zero (R302) for 0mV at TP8 or *LOAD CELL* outputs on Front or Rear Panel (J301 or J303).

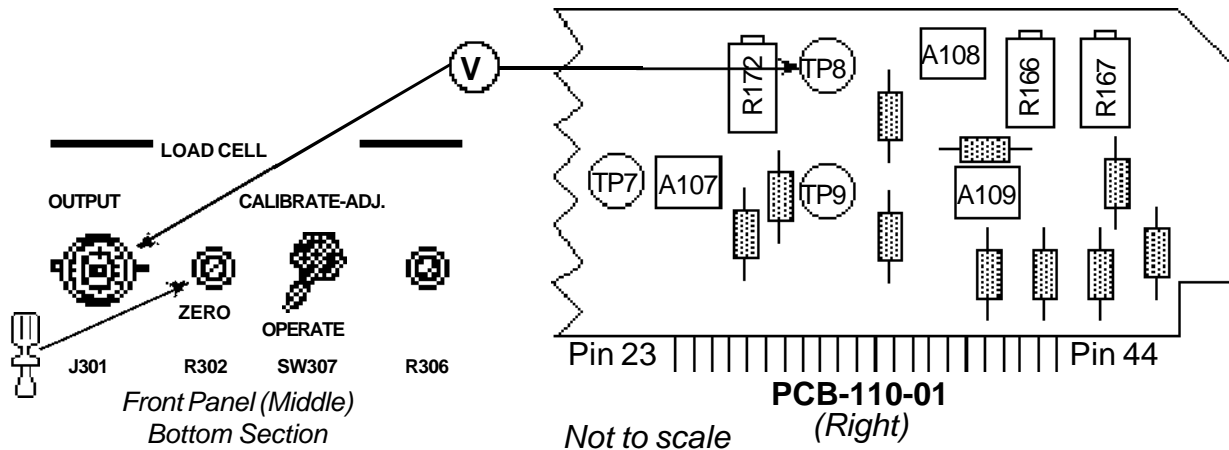

Load Cell Meter Calibration

- Set Load Cell Operate/ Calibrate Switch (SW307) to *CALIBRATE*.
- Adjust the Load Cell Calibration (R306) until the Static Meter reads the Force value (expressed in lbs or Kg) that is supplied on the Load Cell Cal Plug.

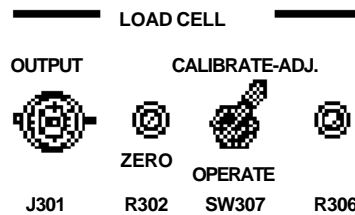

- Repeat Load Cell Zero and Load Cell Meter Calibration until calibration and zero balance is achieved.
- When finished leave the Load Cell Operate/ Calibrate Switch in the *OPERATE* position.

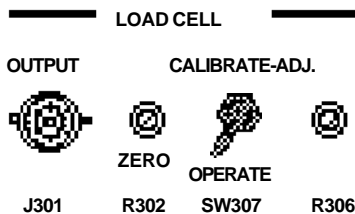

Load Cell Amplifier Scaling

Adjust R166 for Load Cell Calibration voltage at TP8 or *LOAD CELL OUT* using the following formula to determine values:

$$[\text{Calibration Force (on Cal Plug)}/\text{Sens (on Cal Plug)}]$$

Examples:

$$[357\text{lbs per } 300\Omega / 250\text{lbs per Volt}]$$

$$= 1.428 \text{ Volts per } 300 \text{ K}\Omega$$

$$\frac{2558 \text{ Kg}}{1000 \text{ Kg/V}} = 2.558\text{V}$$

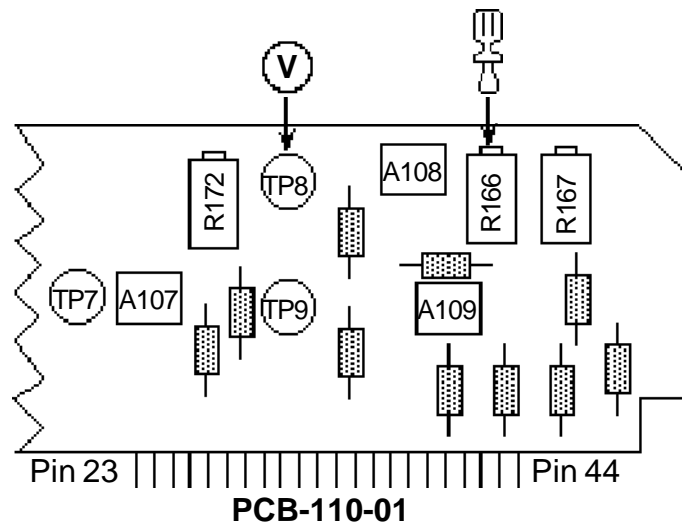

Not to scale

9.3.2. Static Loop Gain Calibration

Set the front and rear panel switches and adjustments as follows:

Excitation Mode Switch	(SW304)	Standby
Load Cell Calibrate/ Operate	(SW307)	Operate
Frequency	(SW309)	Low
Static Preload	(SW310)	Compression
Static Controlled Variable	(SW311)	Internal
Dynamic Controlled Variable	(SW306)	Internal
Static Gain	(SW305)	Variable
Static Set Point Level	(R301)	8.0
Dynamic Set Point Level	(R303)	5.0
Static Gain Level	(R307)	5.0

- Fixture the exciter head for compression into a rigid structure.
- Connect J305, J311, J309 (with BNC Pigtail to static variable input).
- Connect cables to the exciter head.
- Apply a 1.00V peak-peak, 5 Hz square wave to the Program Input (J308).

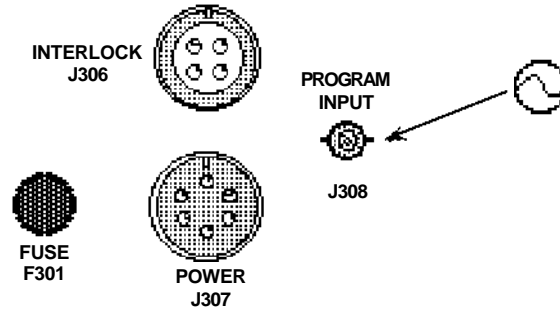

- Start the Hydraulic Supply.
- Set the Excitation Mode Switch (SW304) at *STATIC + DYNAMIC*.
- Adjust Dynamic Setpoint for 1 Volt Plateau to Plateau then adjust (R133) for 20% overshoot (1.2 volts Peak to Peak - as illustrated below). Measure at Load Cell output BNC on Front Panel.

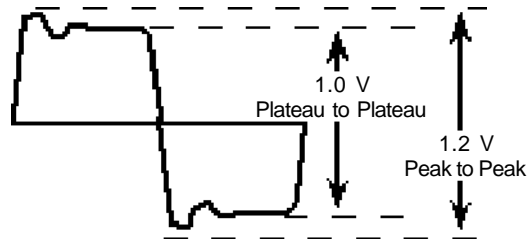

20% overshoot Square wave response for optimum Static Gain Setting.

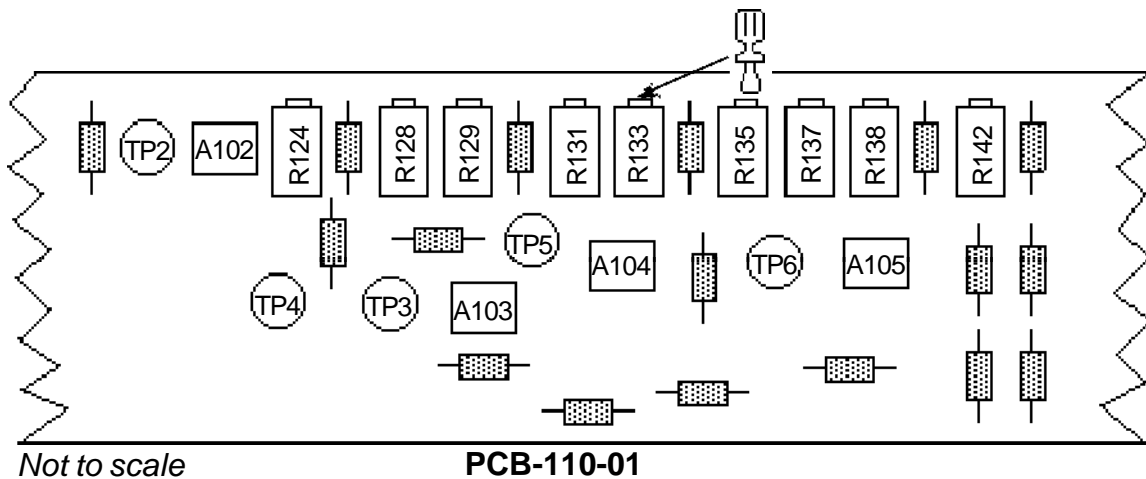

Not to scale

PCB-110-01

9.3.3. Static Set Point Level Calibration

Set front and rear panel switches and adjustments as follows:

Excitation Mode Switch	(SW304)	Static
Static Gain	(SW305)	Fixed
Static Gain Level	(R307)	5.0
Static Set Point Level	(R301)	5.0

- Adjust R107 (Static Cal) for a 50% Static Meter Reading.

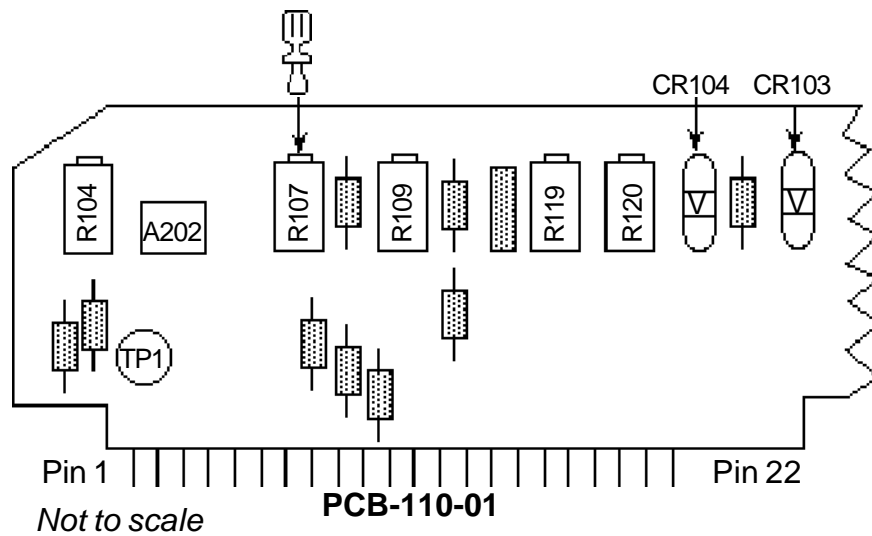

9.3.4. High Frequency Dynamic Level Calibration

Set front and rear panel switches and adjustments as follows:

Load Cell Calibrate/ Operate	(SW307)	Operate
Frequency	(SW309)	High
Static Gain	(SW305)	Fixed
Static Set Point Level	(R301)	8.0
Dynamic Set Point Level	(R303)	5.0

- Apply a 1.000V rms, 60 Hz sine wave to the Program Input (J308).
- Set the Excitation Mode Switch (SW304) to the *STATIC + DYNAMIC* position.
- Adjust R128 for a 50% Dynamic Meter reading (1.77V rms at 110-01-25).

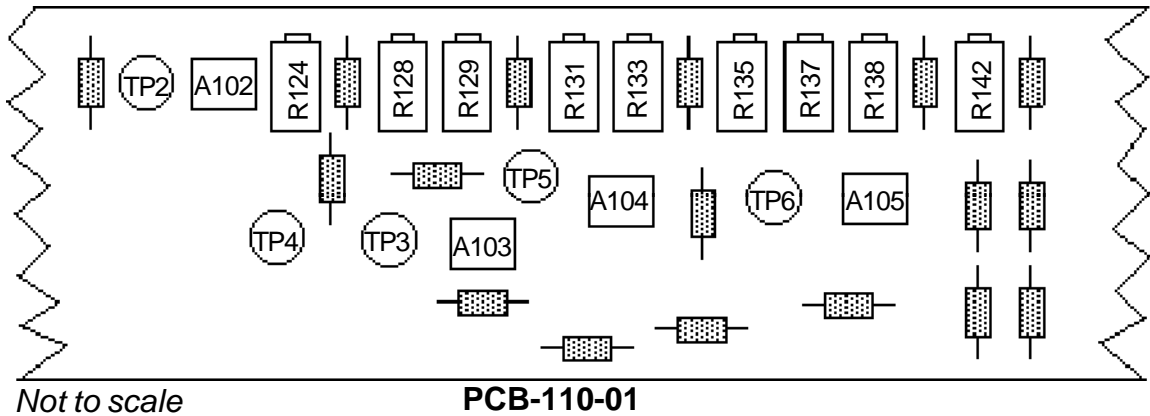

9.3.5. Low Frequency Dynamic Calibration

Set front and rear panel switches and adjustments as follows:

Load Cell Calibrate/ Operate	(SW307)	Operate
Frequency	(SW309)	Low
Static Gain	(SW305)	Fixed
Static Set Point Level	(R301)	8.0
Dynamic Set Point Level	(R303)	5.0

- Apply a 1.000V rms, 10 Hz sine wave to the Program Input (J308).
- Set the Excitation Mode Switch (SW304) to the *STATIC + DYNAMIC* position.
- Adjust R137 for a 50% Dynamic Meter reading (1.77V rms at 110-01-25).

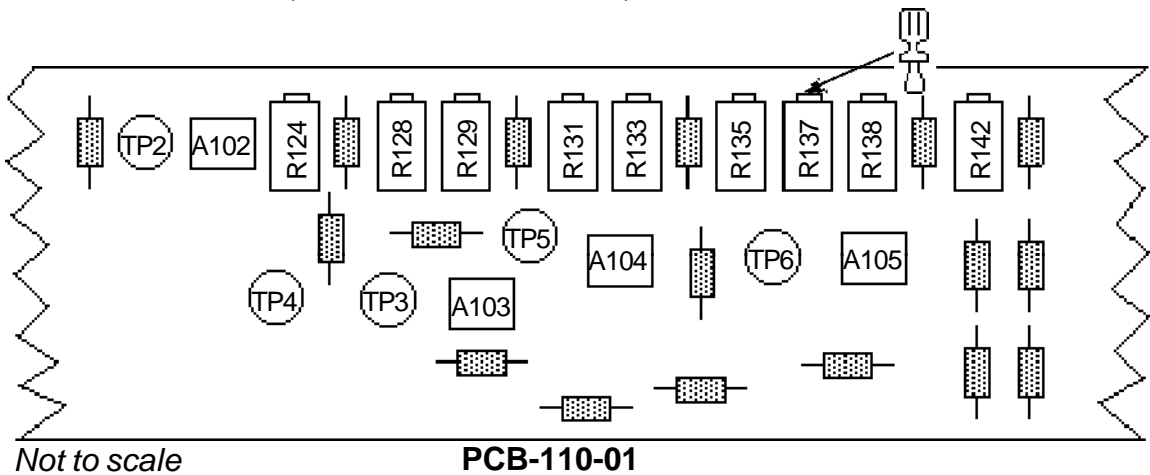

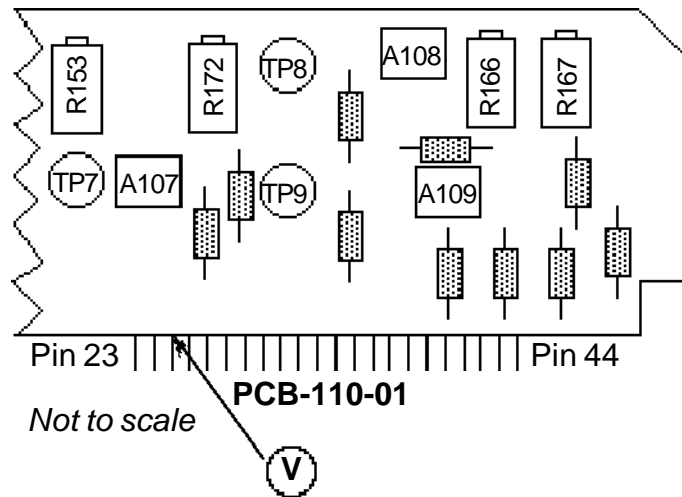

9.4. Displacement Calibration Procedure

Note: Fixture Exciter head for full Stroke.

9.4.1. LVDT Symmetry Verification and Adjustment

Set front and rear panel switches and adjustments as follows:

Excitation Mode	(SW304)	Standby/ Reset
Load Cell Calibrate/ Operate	(SW307)	Operate
Frequency	(SW309)	Low
Static Preload	(SW310)	Compression
Static Controlled Variable (Disconnect Displacement		
Feedback Signal for this set up)	(SW311)	External
Static Gain	(SW305)	Variable
Static Set Point Level	(R301)	10.0
Static Gain Level	(R307)	5.0

- Set the Static Preload Switch (SW310) to *TENSION* (CW). The head should fully extend.
- Set the Static Preload Switch to *COMPRESSION* (CCW). The head should fully retract.
- While monitoring 110-01-38 (WHT/ YEL wire) with a DC volt meter, you should observe a **NEGATIVE** voltage when the head is fully extended and a **POSITIVE** voltage when the head is retracted. These two voltages should be equal and opposite in magnitude.

NOTE: The importance is in the equality of the numerical values not in their values. (i.e. +3 and -3 are just as good as +6 and -6)

- If the balance is off by more than 10%, the LVDT Rod or the position of the LVDT on the Exciter Head should be adjusted.

WARNING

Do not make mechanical adjustments to an exciter head while the hydraulic power supply is active. Serious personal injury could result.

9.4.2. Displacement Zero Calibration

- Set the Static Setpoint (R301) to 10.0.
- Set the Excitation Mode switch (SW304) to *STATIC*.
- Set the Static Preload switch (SW310) to *TENSION*.
The head should fully retract.
- Adjust R172 for 0mV at TP7.

9.4.3. Displacement Scaling Calibration

- Set the STATIC PRELOAD SWITCH (SW310) to *COMPRESSION*. The head should be fully extended.
- Adjust R153 for 10.000V at TP7.
- The static meter should read 100% full scale deflection.
- Repeat steps 4.2. and 4.3. until balance is achieved.

9.4.4. Final External Static Control Variable Calibration

- Verify 10.000V DC at TP7 (accurate to within 1.0mV)
- If necessary, adjust the Static Variable Cal (R311) for 0.5V DC at 110-01-28

9.4.5. Dynamic Displacement Calibration

Set front and rear panel switches and adjustments as follows:

Frequency	(SW309)	Low
Power Amp Input	(SW312)	Internal
Static Preload	(SW310)	Compression
Static Controlled Variable	(SW311)	External
Dynamic Controlled Variable	(SW306)	Internal
Static Gain	(SW305)	Variable
Static Set Point Level	(R301)	5.0
Dynamic Set Point Level	(R303)	5.0
Static Gain Level	(R307)	5.0

- Set the Excitation Mode Switch (SW304) to the *STATIC + DYNAMIC* position.
- Apply a 1V rms, 5 Hz sine wave to the Program Input (J308).
- Adjust R135 for a 5V peak-peak at TP7.

9.4.6. External Static and Dynamic Set Point Calibration

There are no adjustments or calibrations for the External Static and Dynamic Set Point inputs. Verify that the static controlled variable achieves full scale output with a +5VDC, +/-5% signal and that the dynamic controlled variable achieves full scale output with a -5VDC, +/-5% signal.